

1. Introduction

Hubs for Circularity (H4C) aims to enhance the exchange of resources and drive innovation by fostering industrial symbiosis across regions.

Digital Twins (DTs): Virtual representations of physical systems that simulate, monitor, and visualise complex interactions.

Research Gap: However, existing decision support tools for industrial symbiosis lacks predictive and/or spatial integration.

Research Aim: This study develops a data-driven Digital Twin for a green hydrogen system in Almelo, linking renewable energy systems with circular flows of hydrogen, oxygen, heat, and water to enable scenario-based simulation and system predictions.

2. Definition, Motivation, and Objective

Digital Twins

What?

A **virtual model of a physical system** that simulates its behaviour, performance, and interactions over time [1]

Goal

✓ Create an interactive DT linking renewables, electrolysis, and circular flows

Why?

- ❑ Absence of operating industrial symbiosis DTs
- ❑ Most tools functions for proof-of-concept purposes only
- ❑ Limited support for scenario-based planning in IS and H4C

✓ Simulate and evaluate resource reuse, spatial trade-offs, and system interactions

✓ Enhance communication and assessment within IS networks

3. Research Methods

PHASE I: Preparation

Stakeholder Meetings
Case Study

PHASE II: Data Collection

System Parameters
Causal Loop Diagram

PHASE IV: Assessment

Evaluation
Limitations

PHASE III: Digital Twin Design

Dashboard Design
3D City Modelling

Research-in-Progress

References and Acknowledgments

[1] University of Twente (2024). Digital Twin GeoHub.

[2] Deck.gl (2024). Using deck.gl with Mapbox.

This work is done and presented by **Hisham Afash** under the supervision of **Mila Koeva, Yifei Yu, and Devrim M. Yazan**.



This project has received funding from the European Union's HORIZON Research and Innovation Actions programme under grant agreement number 101138473



4. Phase I: Case Study in Almelo Dutch Hub

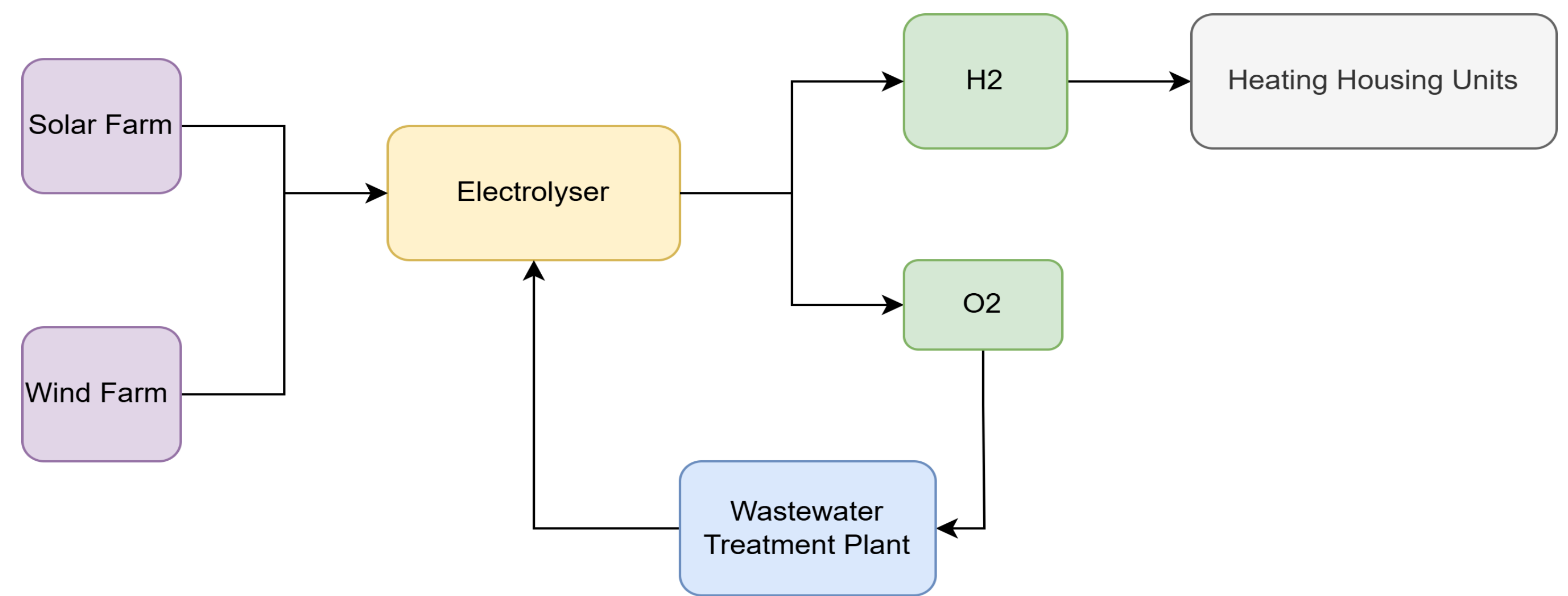

5. Phase II: Causal Loop Diagram and System Parameters

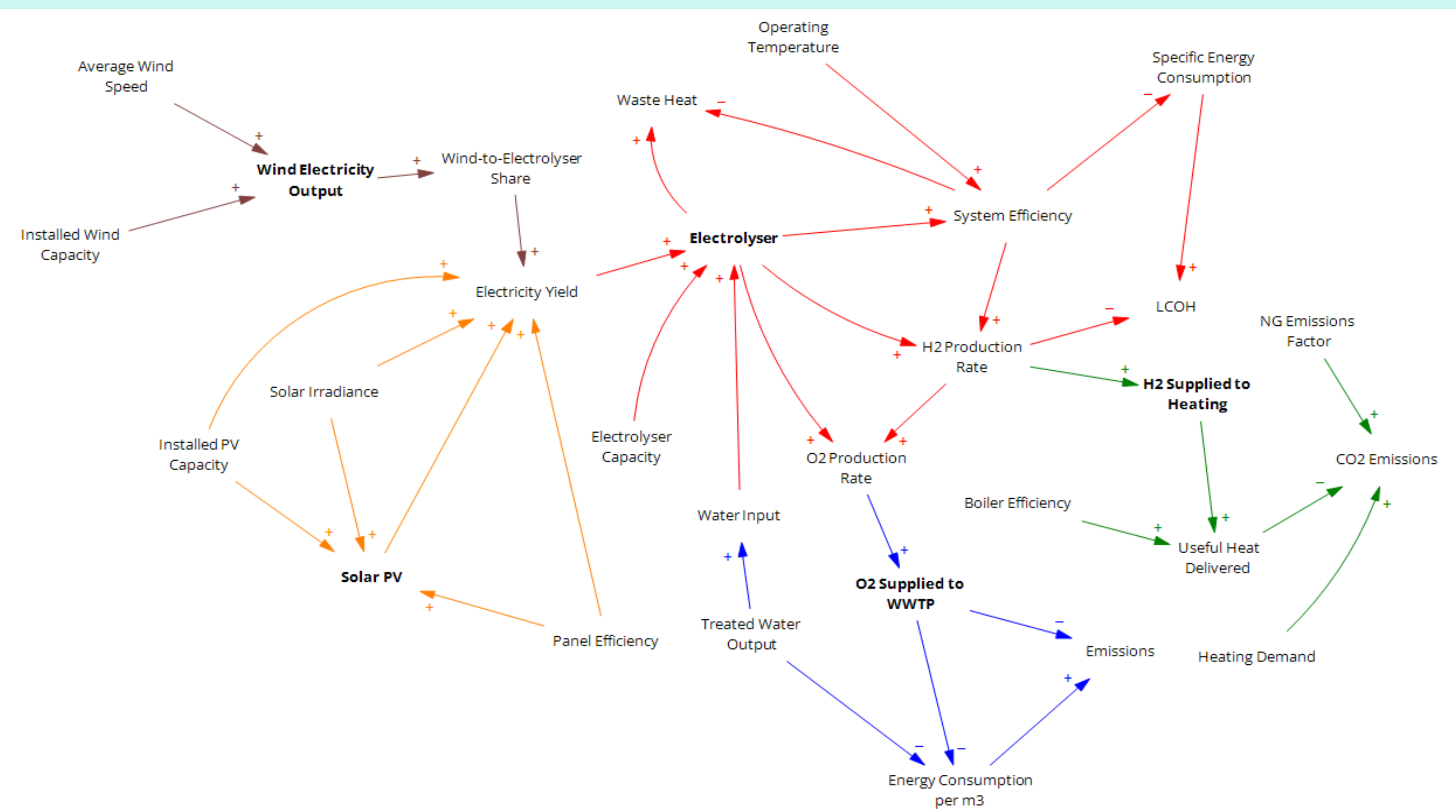

6. Phase III: Digital Twin Design and Map Integration [2]

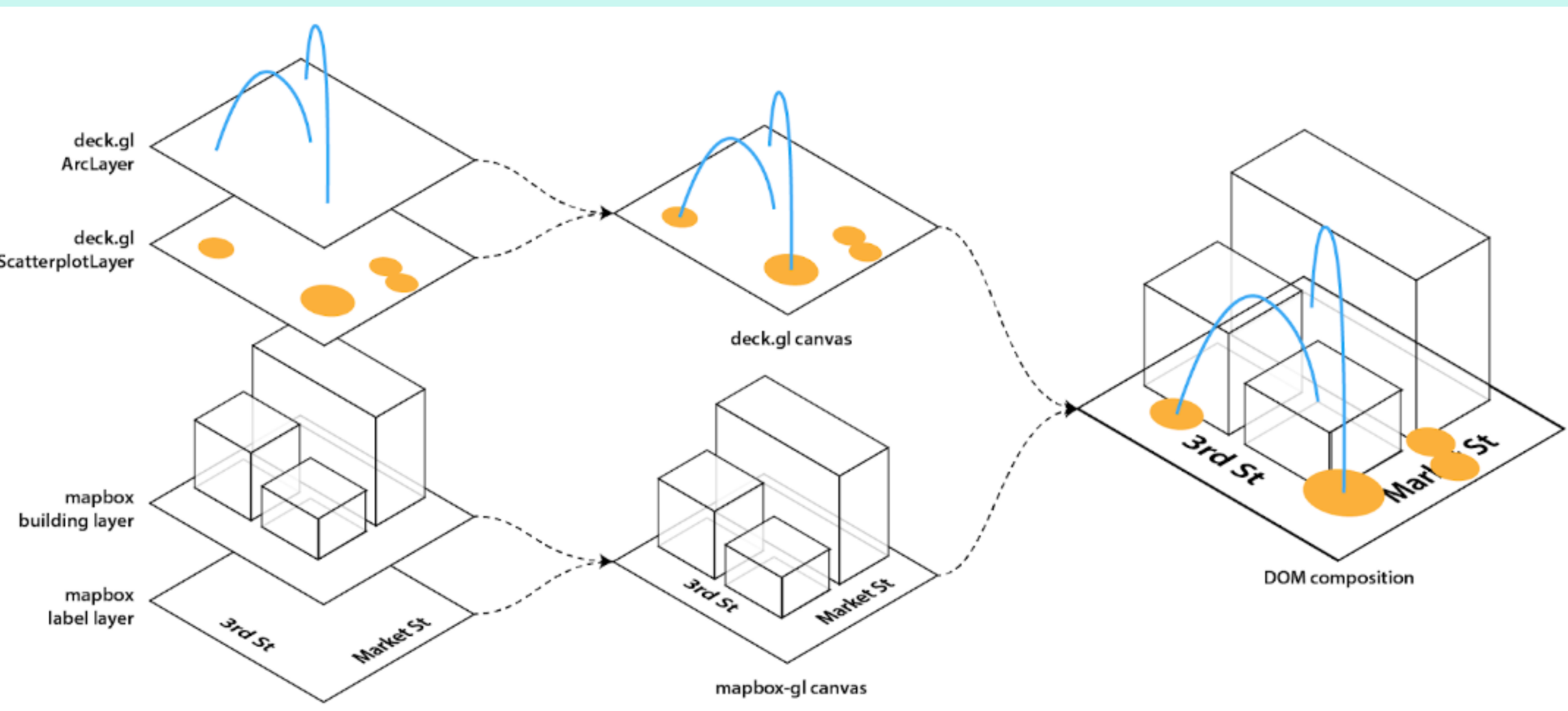

7. Results and Discussion

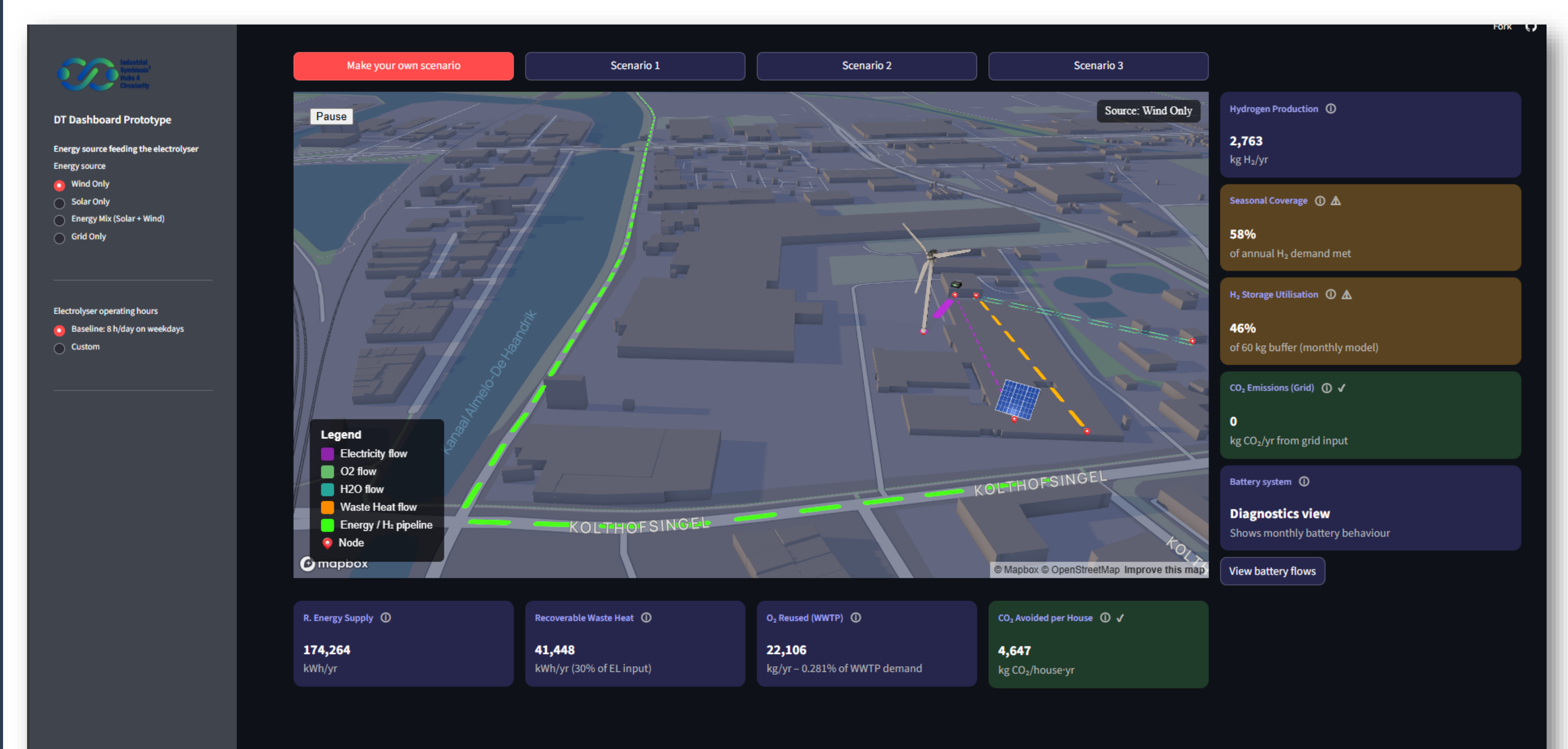

- Data-driven DTs supporting industrial symbiosis systems
- Digital dashboard and geospatial map for scenario analysis
- KPI calculation and system behaviour analysis
- Enhances planning and communication within H4C



Guiding the Twin Transformation: Digital Technology-enabled Circular Business Models (TT-CBM)

Dr. Banu Aysolmaz, Information Systems, IE&IS

Research Context

This research facilitates the twin transformation, i.e., the **digital and sustainability** transformation in tandem, for manufacturing **value chains** to realize circularity strategies with a business model lens. It guides the operationalization aspect of a business model, i.e., designing **processes** that realize circularity strategies and use **digital technologies**, to enable systemic and aligned twin transformation.

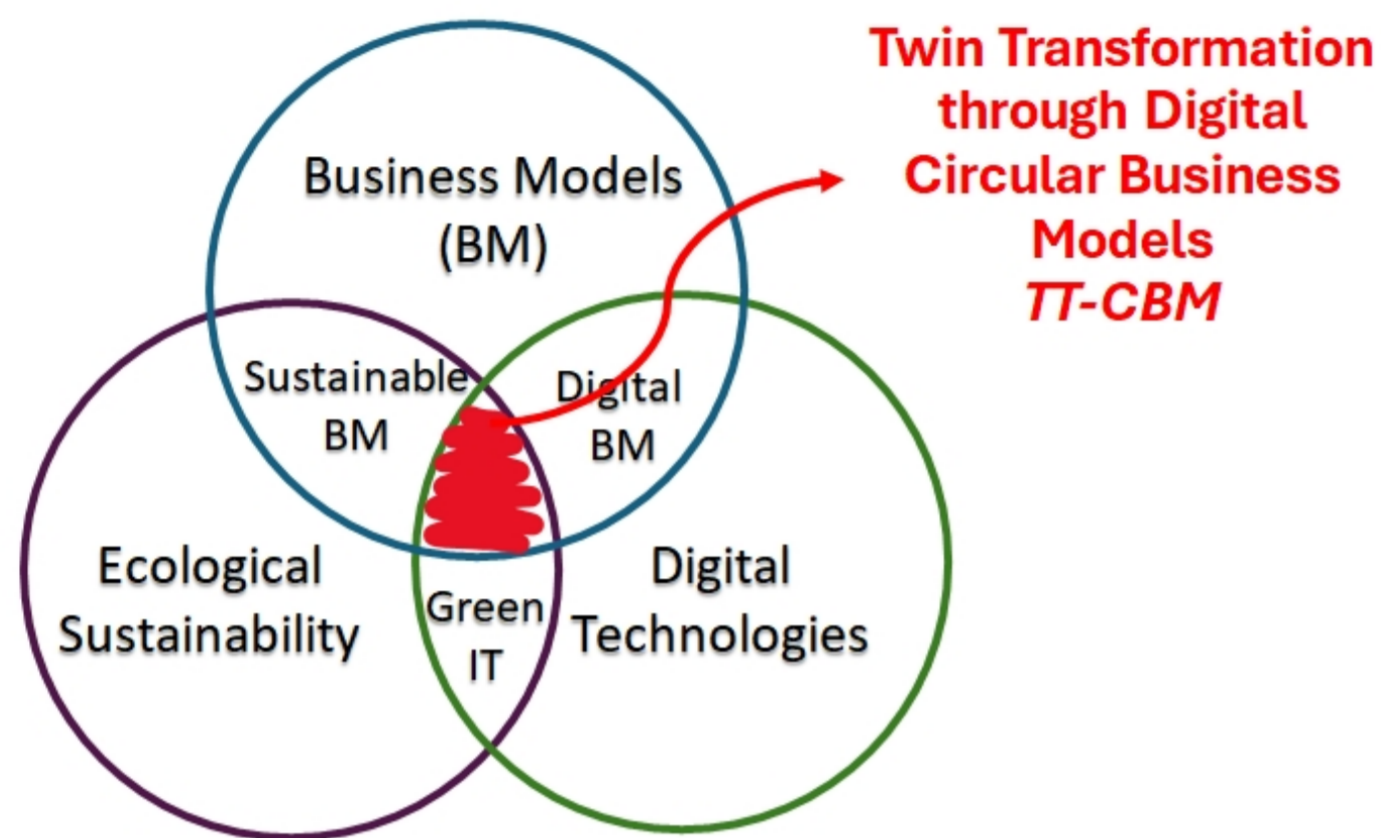

Our Approach

We develop methods for the **operational design** of collaborative business models for circularity and sustainability. These methods help to specify business model elements in a collaborative setting, including:

- network's **circular & sustainable value proposition** and **costs and benefits** considering financial, environmental, and social aspects.
- identification of relevant circularity strategies (i.e., **R-ladder**) and **digital technologies** (e.g., data analytics, product passport, blockchain, IoT, and data spaces),
- evaluation** of business models using dynamic modelling and advanced analytical techniques for their economic viability and environmental and societal impact, and
- definition of **Key Performance Indicators (KPIs)** at the network and organizational levels to evaluate and monitor the performance of the business model throughout its lifecycle.

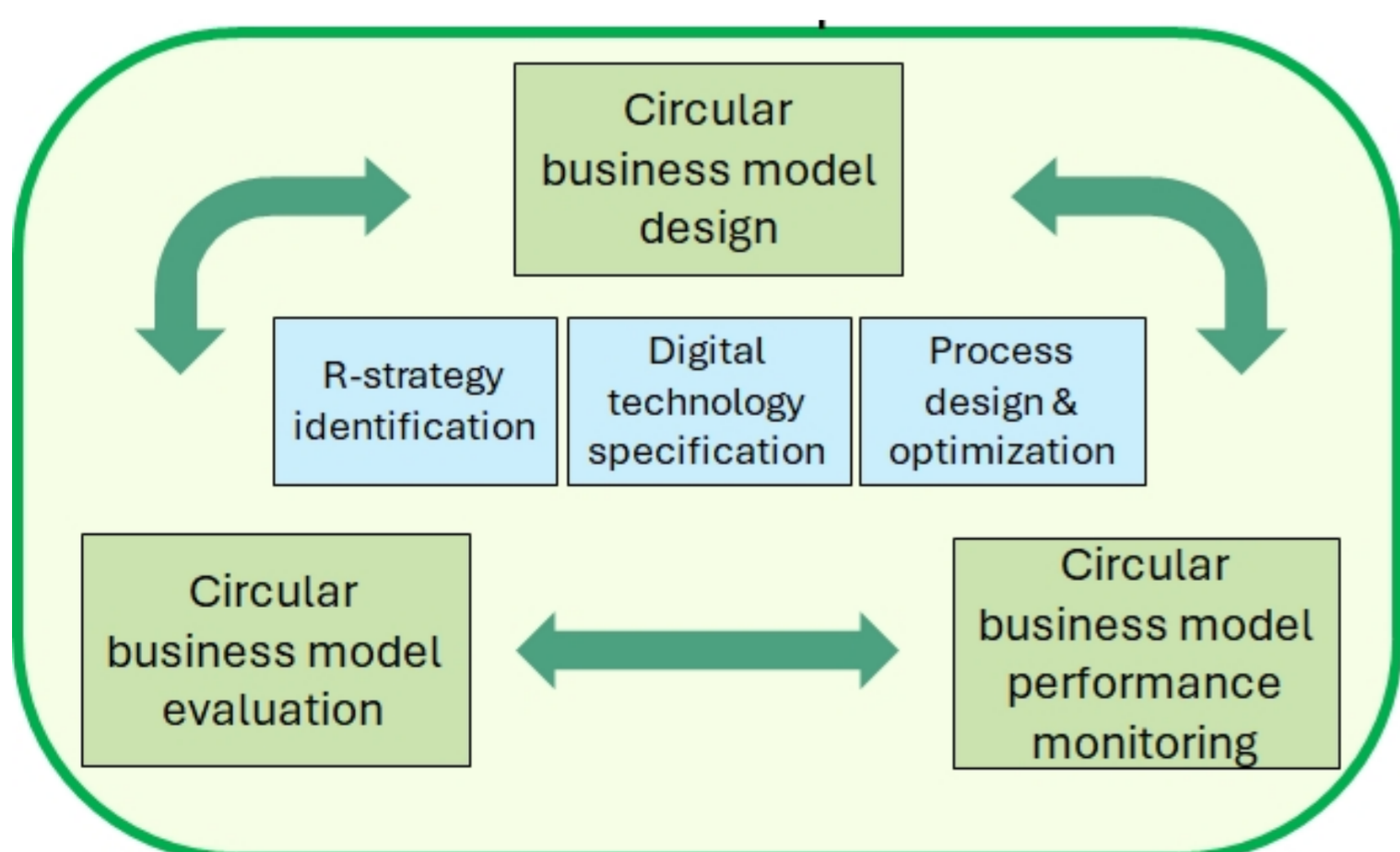

Contact & Team

Banu Aysolmaz & Oktay Turetken
Business Engineering Cluster
Information Systems, IE&IS

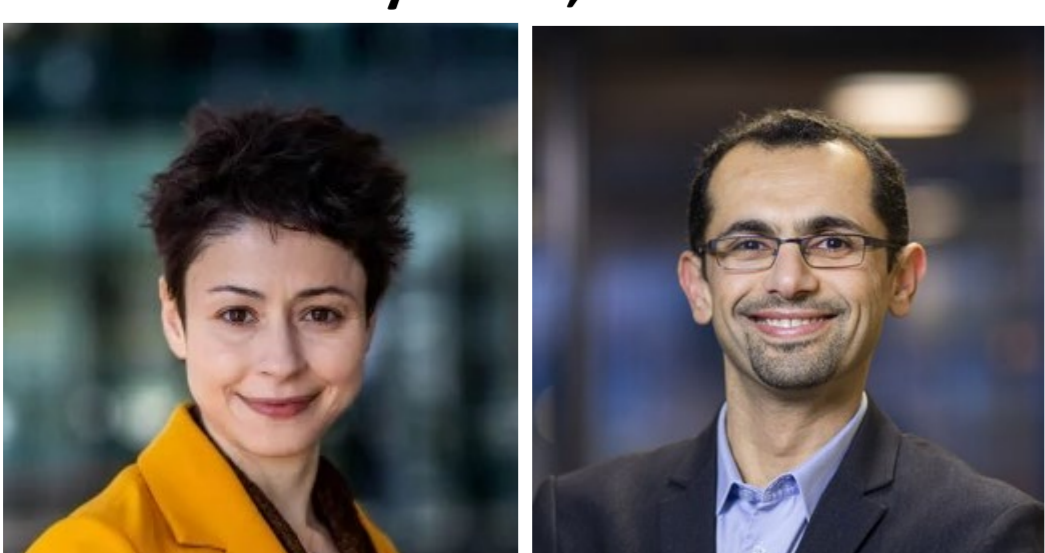

Example Studies

*Reference Blockchain-enabled Collaborative Business Model for Traceability and Transparency in Circular Value Networks**

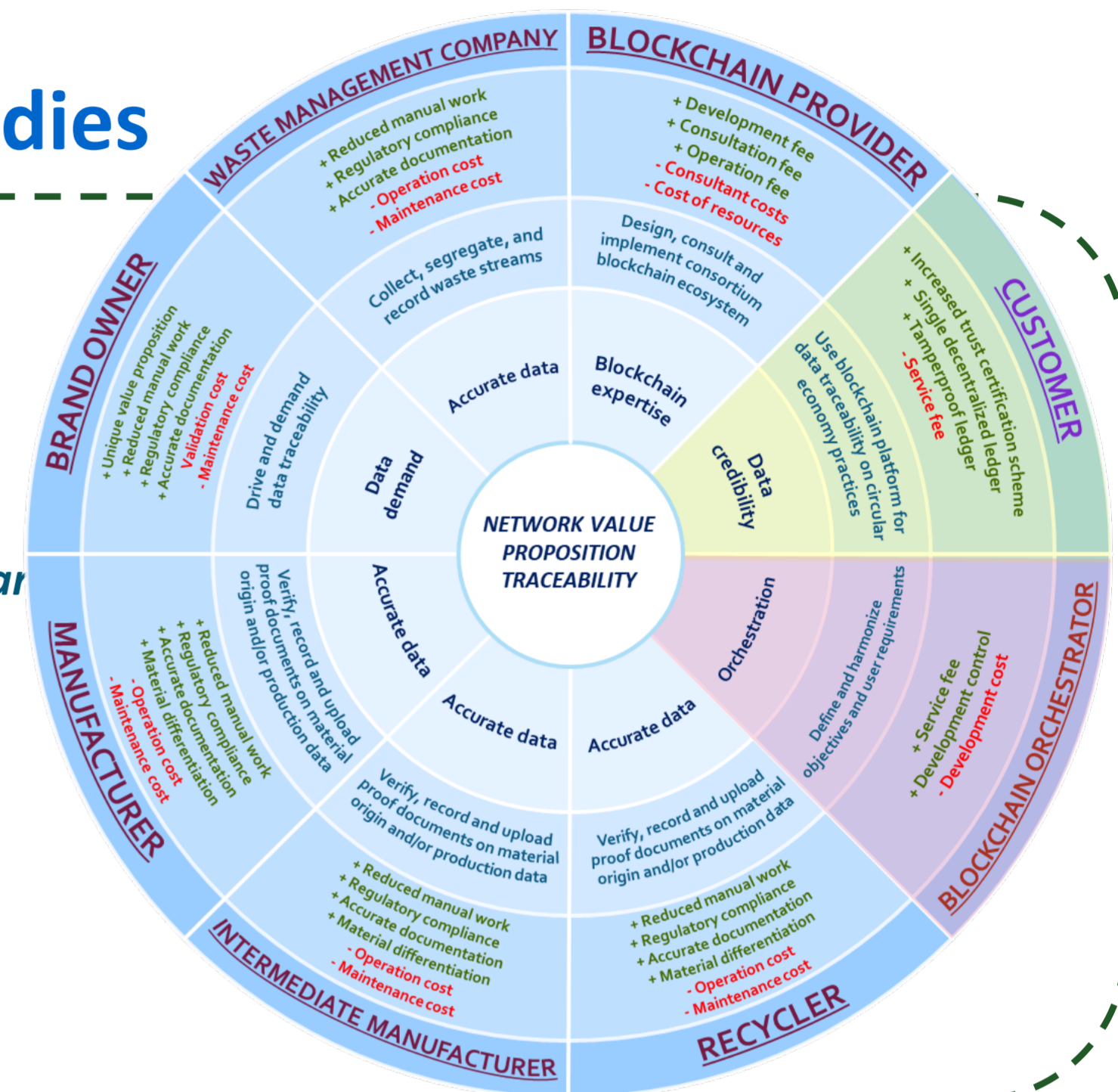

Defining Key Performance Indicators for Collaborative Business Models

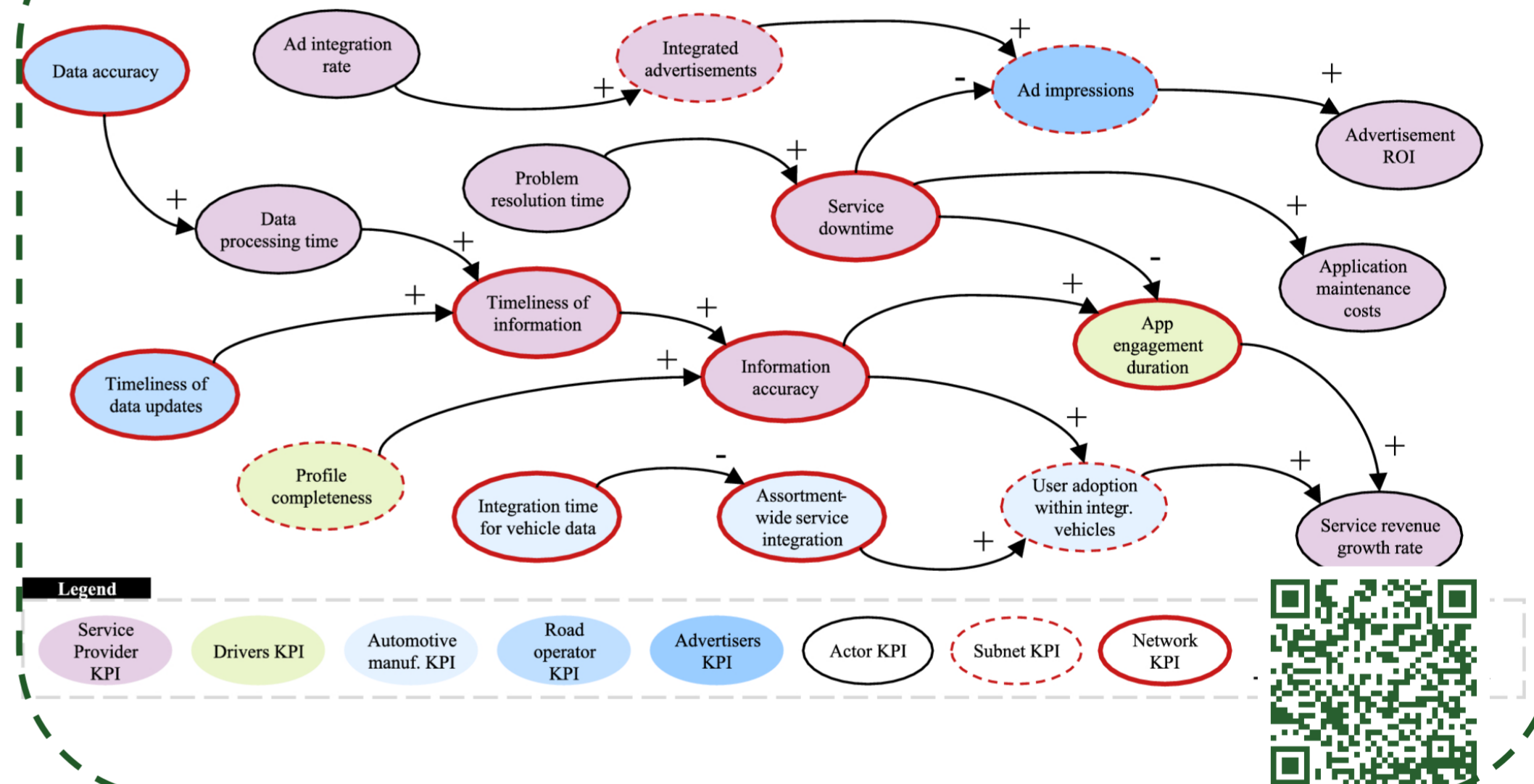

Process Mining Guidelines for Greenhouse Gas Emission Management in Production Processes

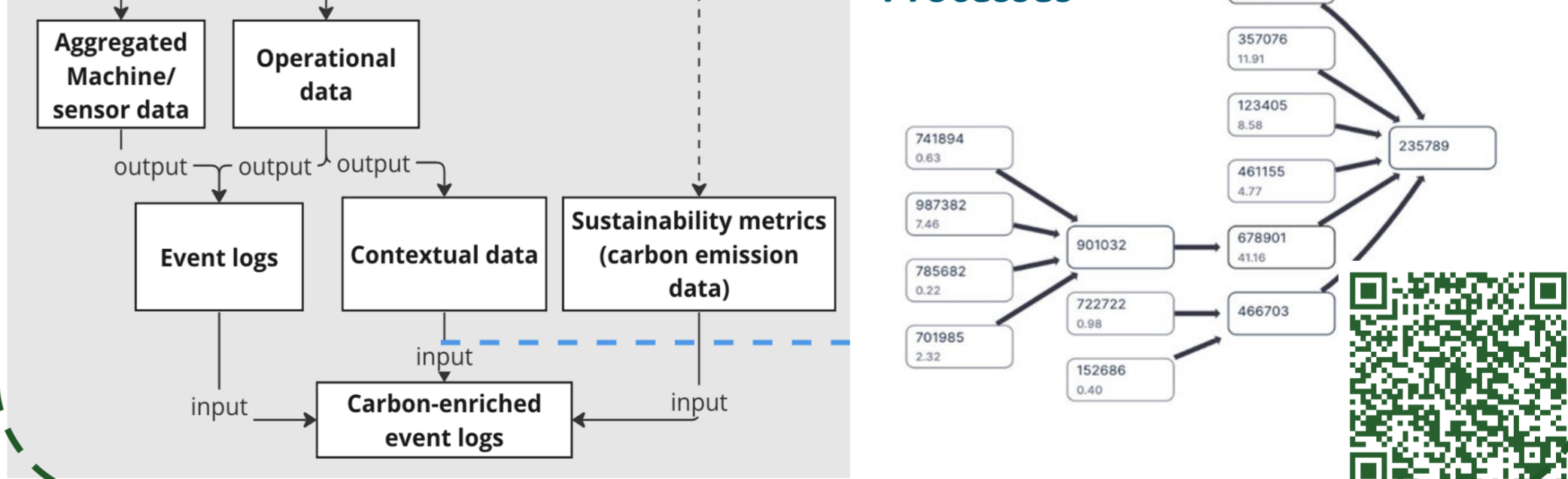

System Dynamics for Selecting Key Performance Indicators for ESG

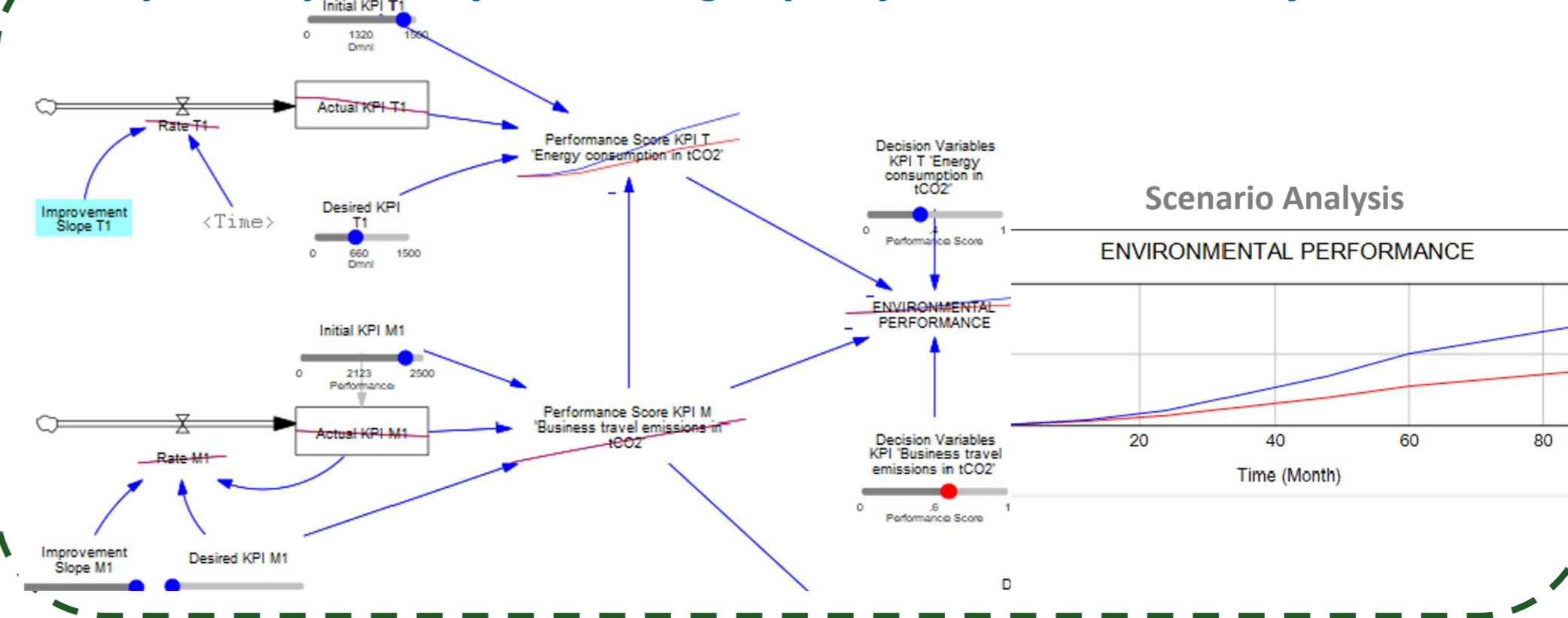

Produce Smarter, Consume Wiser- Enabling Responsible Food Systems in

The Netherlands

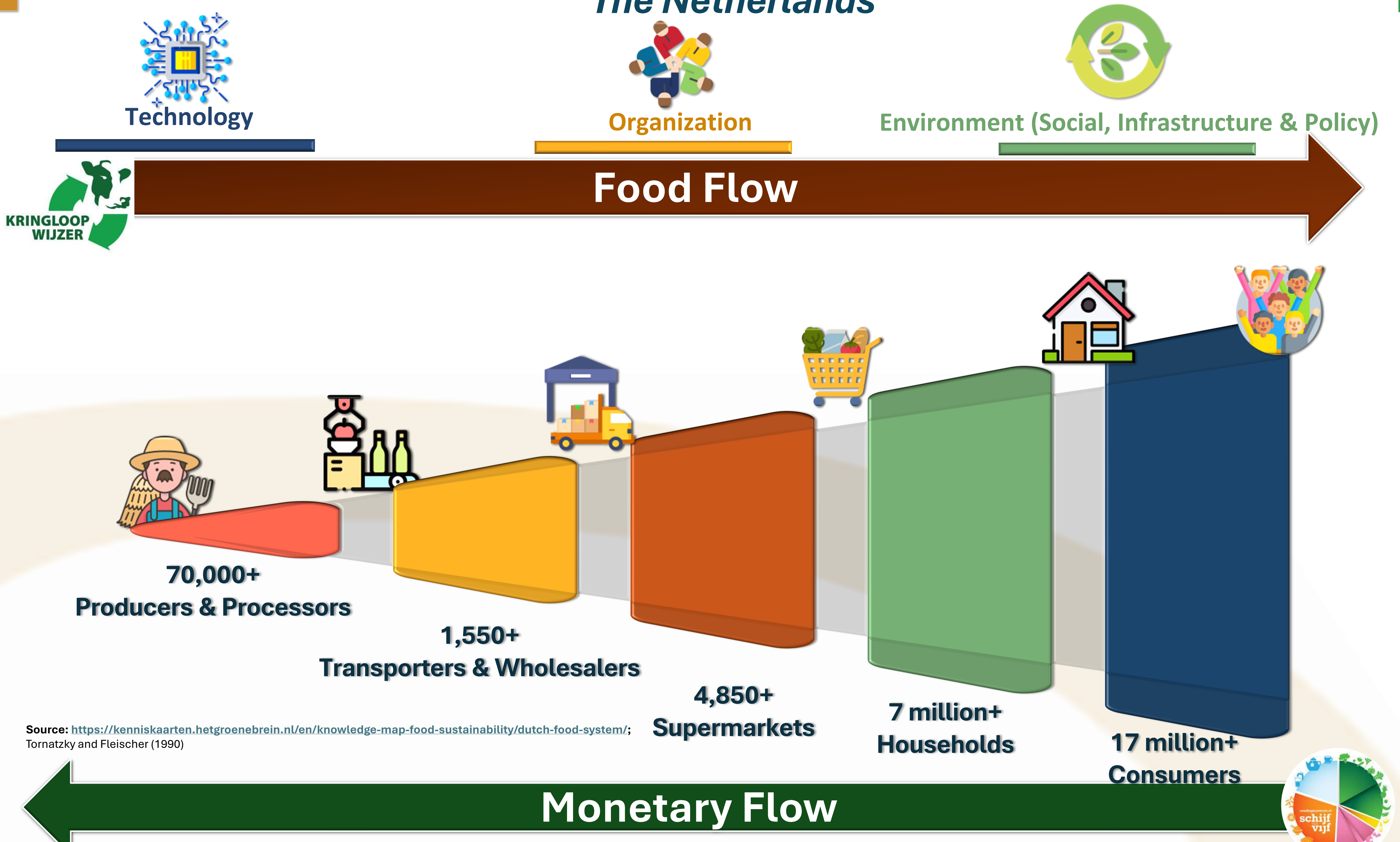

Stakeholder Engagement

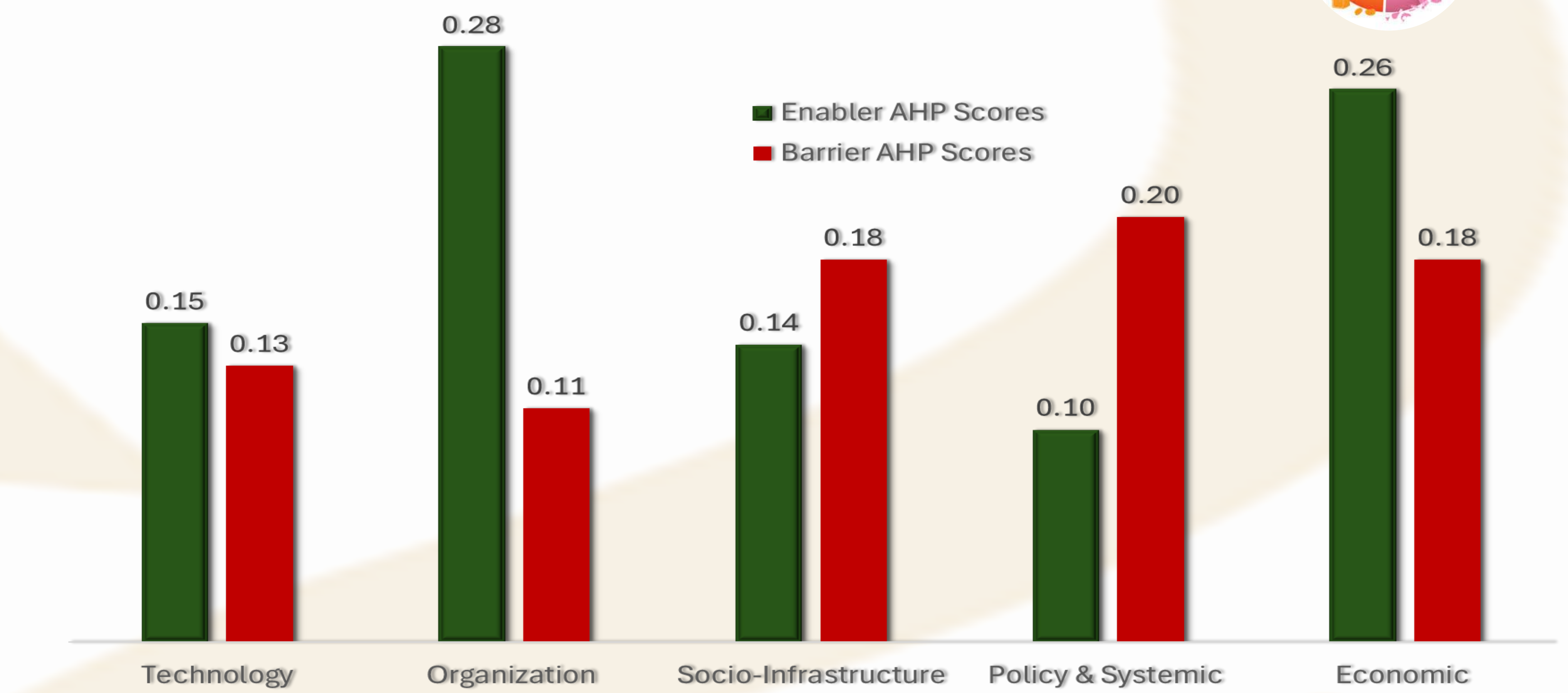

Derived from a multi-stakeholder AHP survey (n=12 experts; 700 enabler comparisons). Analysis supported by consistency ratio < 0.1.
While Policy is essential for direction, Organizational alignment and Economic feasibility determine action.

Calls To Action

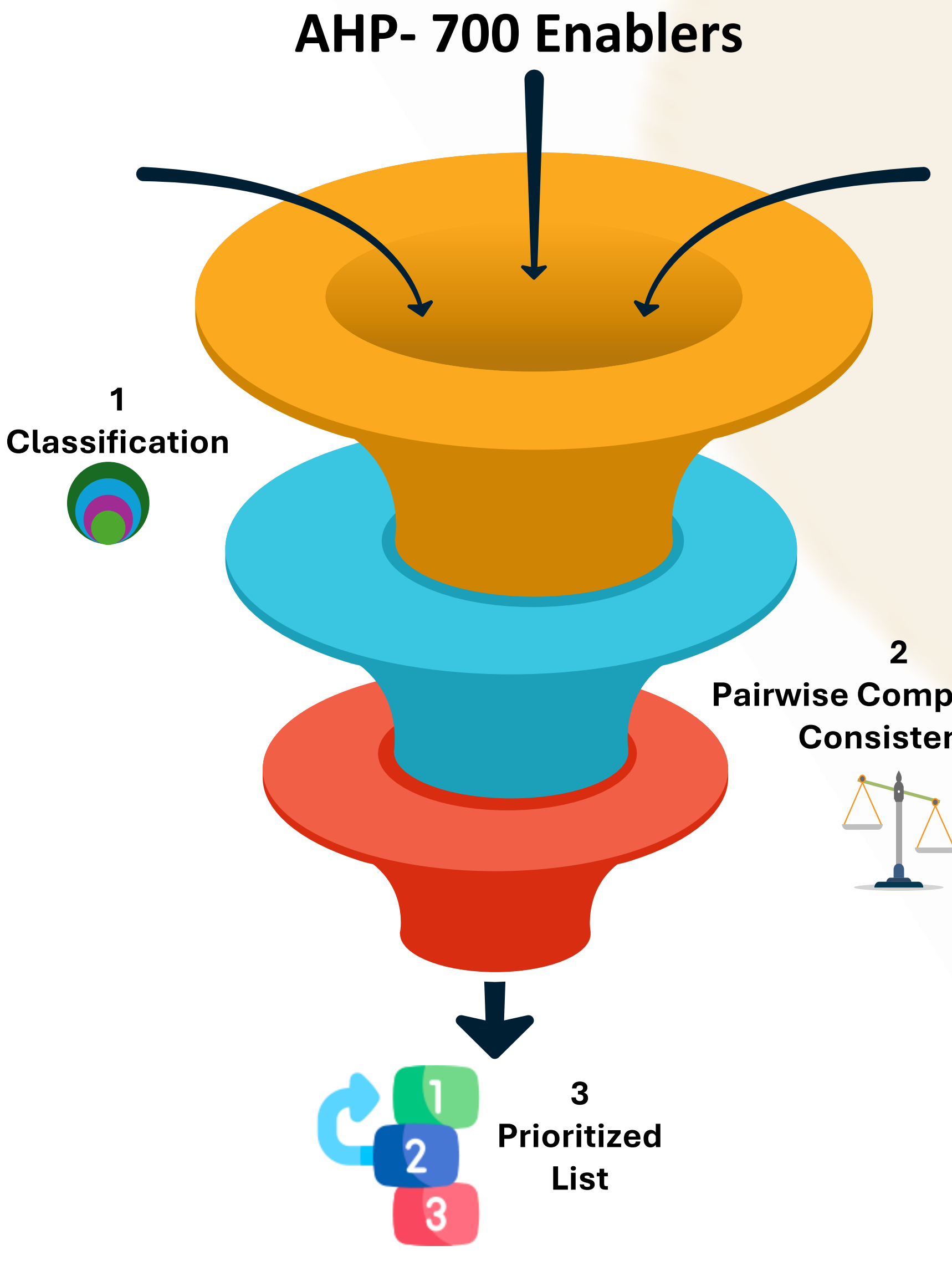

- 1 **Shift incentives from quantity to quality production**
In the **Agent-Based Model**, agents (producers, firms) shift strategies from volume-driven to value-driven production under economic and organizational enablers
- 2 **Make organizations the backbone of the sustainability transition**
Life Cycle Analysis evaluates footprint reduction metrics (CO₂, energy, water) across production-consumption loops
- 3 **Use technology to connect sustainable intent and results**
Statistical Package for Social Sciences links these LCA outputs with economic enablers to identify incentive structures that reward environmental efficiency rather than sheer production volume, **aligning directly with SDGs 3 & 12**
- 4 **Reward footprint reduction, not output inflation**

Integral Waste Valorization Systems:

Sustainable network design from economic and environmental perspective

✉ furqan.hala@wur.nl



Ahmad Furqan Hala, Petronella Margaretha Slegers, Argyris Kanellopoulos, Renzo Akkerman
Operations Research and Logistics, Wageningen University and Research, Wageningen, The Netherlands

INTRODUCTION



Waste negatively affect human health and environment when not managed adequately.

Valorization to recover high value materials is preferred. Integration and collaboration is necessary to improve resource recovery efficiency.

Designing integral valorization network needs to also consider the environmental burden from the systems.

Current disposal from total waste:

70%

Profit increase through integration:

↑ 3x

What are the trade-offs?

?

OBJECTIVE

To measure trade-offs between economic and environmental indicators for integral waste valorization systems, considering the potential for secondary valorization of the side streams

METHODOLOGY

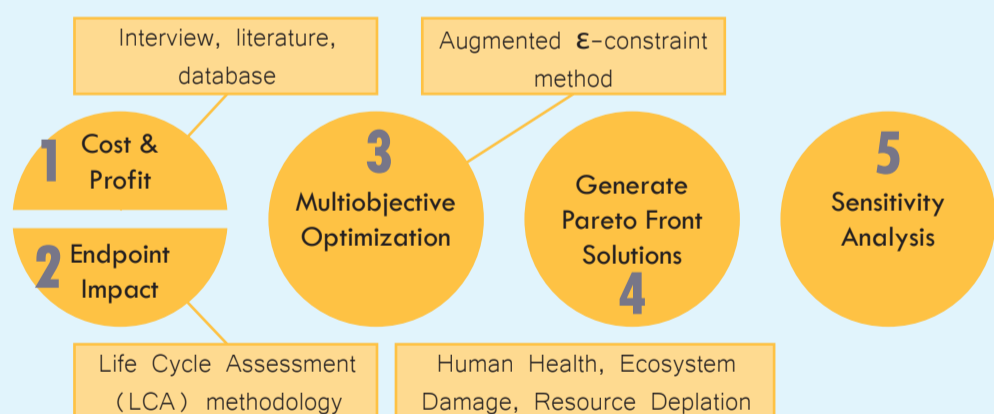

CASE STUDY: THE NETHERLANDS

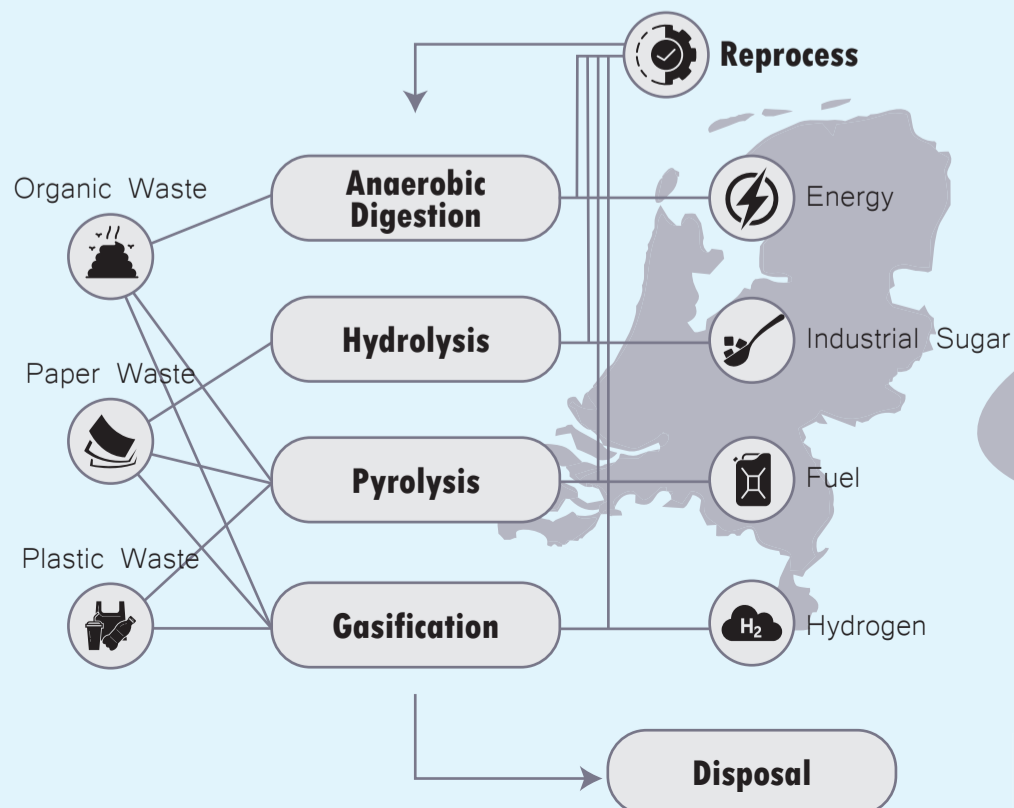

RESULTS AND DISCUSSION

Integral System

Performance depending on chosen pathway and integration, compare to reference system

Varied across different objectives.

Reference System

Valorization of waste individually without integration and collaboration

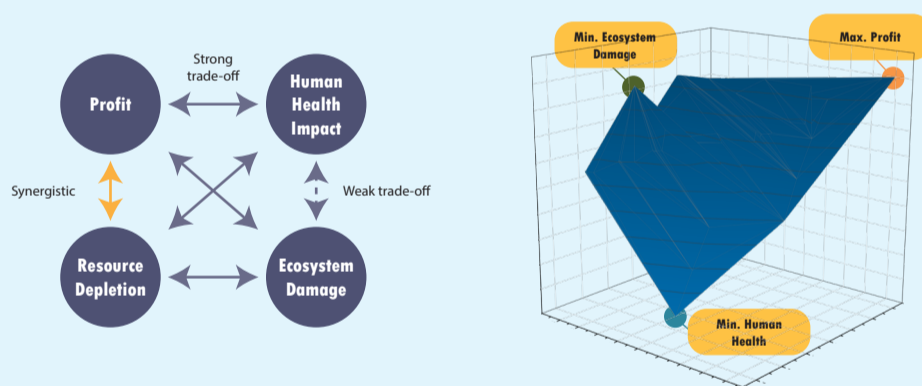
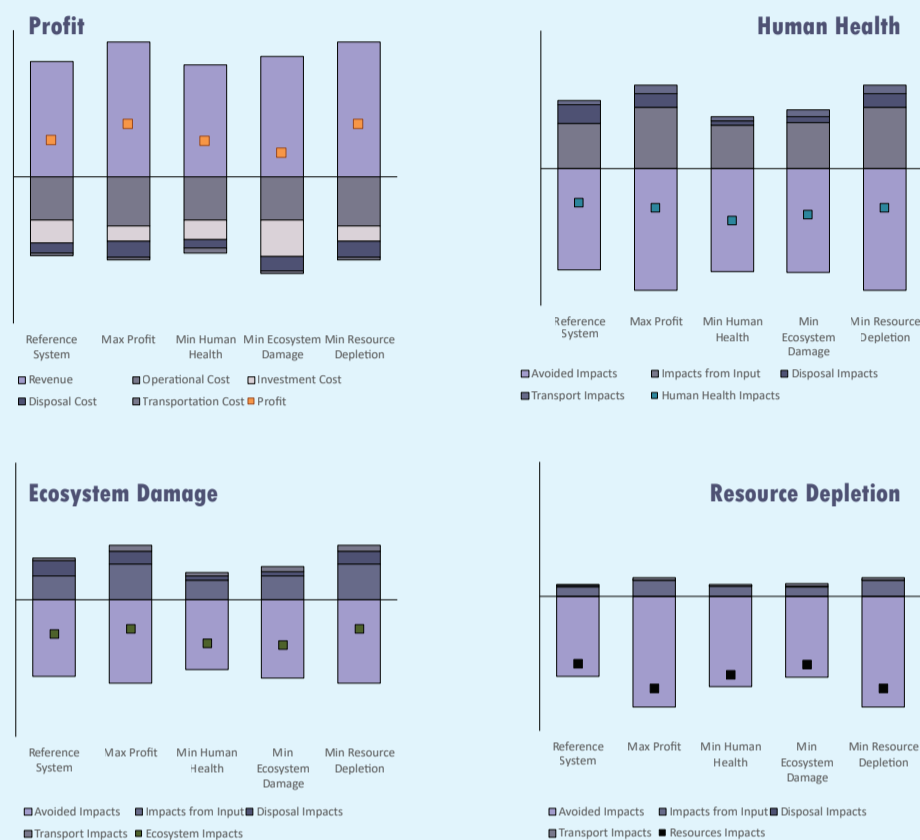

CONCLUSION

There are strong and weak trade-offs, as well as synergistic relationships among different objectives

Avoided impacts from substitution of recovered materials have the most contribution for the environmental impacts.

Coordination of the technology is essential to maximize utilization of waste resources and further improve the overall environmental impacts.

ACKNOWLEDGEMENT

This project is co-funded with subsidy from the Topsector Energy by the Ministry of Climate Policy and Green Growth.



Refurbish-to-Lease Business for Enhancing Healthcare Accessibility

Zhongxin Hu¹, Christina Imdahl¹, Yeqing Zhou², and Zümbül Atan¹

¹OPAC group, Eindhoven University of Technology, ²Erasmus University Rotterdam

Background

Global Healthcare Disparity

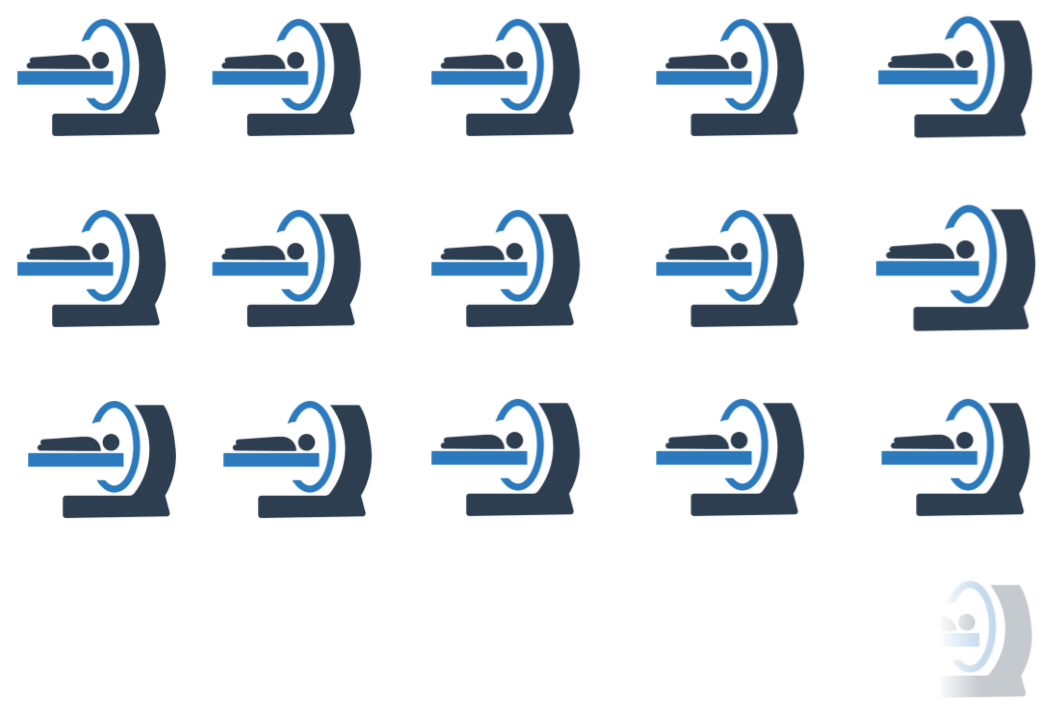

15.3 MRI units/1 million ppl¹
Netherlands

0.48 MRI units/1 million ppl²
Ghana

Inequality in **access to medical equipment** is a key driver:

The Netherlands has 13.4 MRI units per million people, nearly **32 times** Ghana's 0.48 units per million, the highest in West Africa.

Current Business Model

Servitization Model

In well-served markets

OEMs (e.g., Philips) retain **ownership** of the equipment and handle maintenance and end-of-life replacement.

Challenge: Medical equipment remains in wealthy markets.

Leasing Model

In underserved markets

OEMs contract for a fixed term to supply, install **new equipment**, and provide ongoing maintenance via a **fixed, recurring payment**.

Challenge: Local hospitals face significant **financial hurdles** due to the high equipment costs and large capital payments.

Refurbish-to-Lease Model

Research Questions:

- (1) How can *servitization* be leveraged to enhance *leasing*?
- (2) How to model OEM's *refurbish-to-lease* decision to maximize profit?
- (3) What are the implications of the optimal decision strategy?

Refurbish-to-Lease Model

Servitization

in a well-served hospital

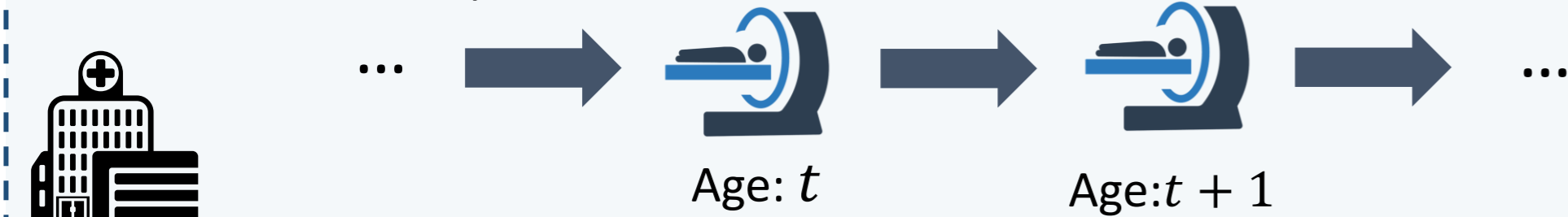

Refurbish-to-Lease (RTL)

Leasing

in an underserved hospital



OEM's Dynamic Decision-Making

Trade-off of RTL

- 👍 Leasing Revenue (depends on p_t)
- 👎 Refurb. Cost (depends on t) + Equip. Cost + Oppo. Cost \rightarrow (t + 1)

Finite-state Markov Decision Process (MDP)

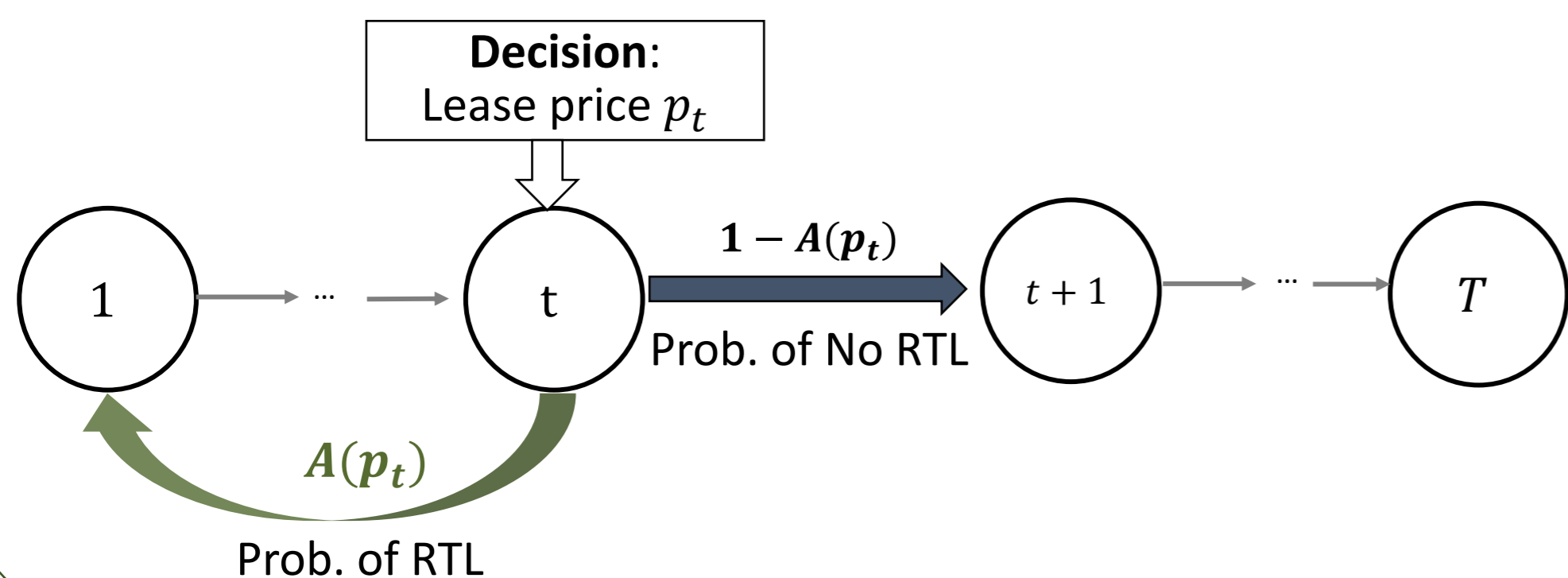

Results

Equipment Replacement Implications

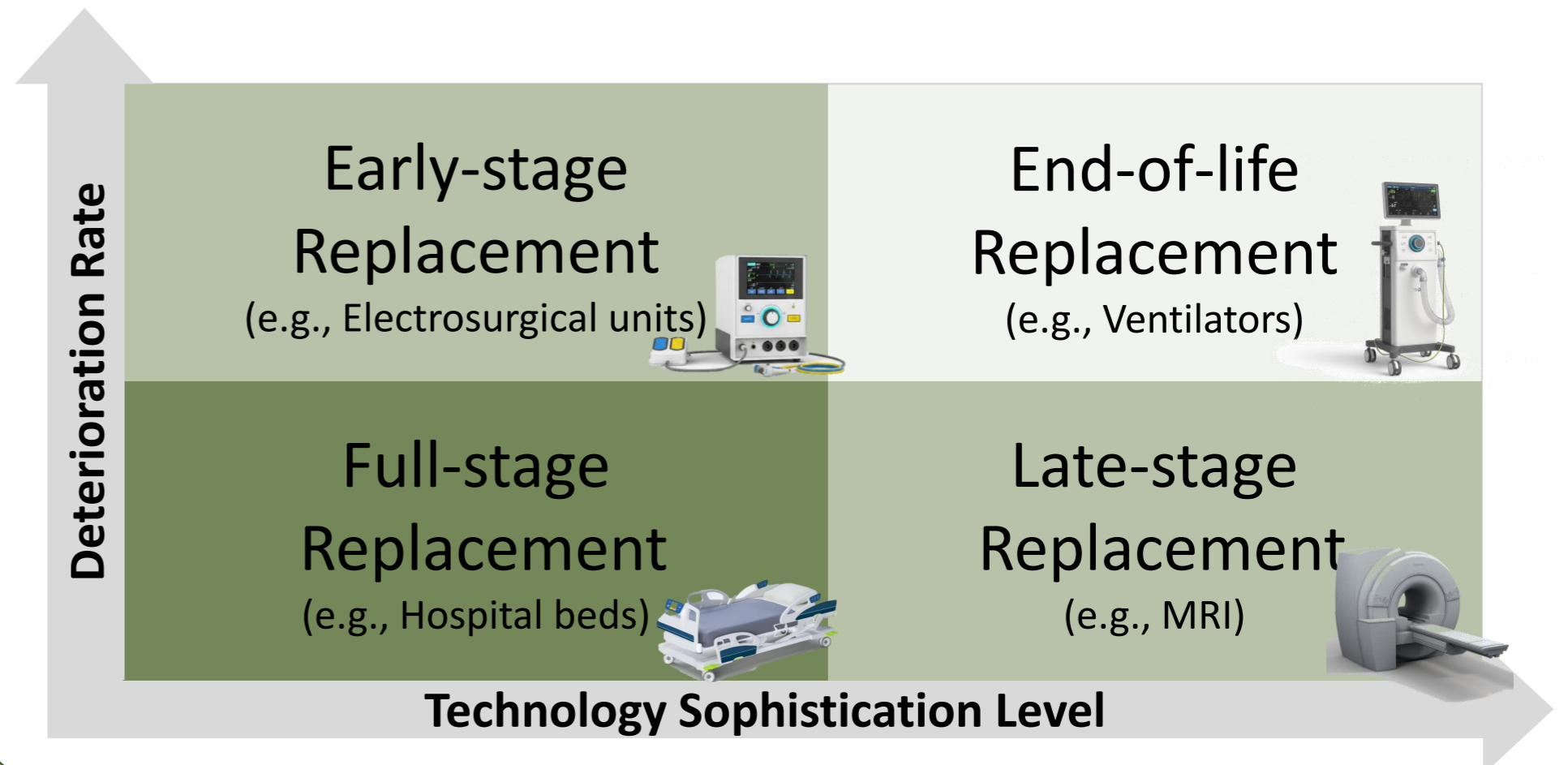

Equipment Allocation Implications

The pyramid shows a tiered hospital structure in underserved markets.

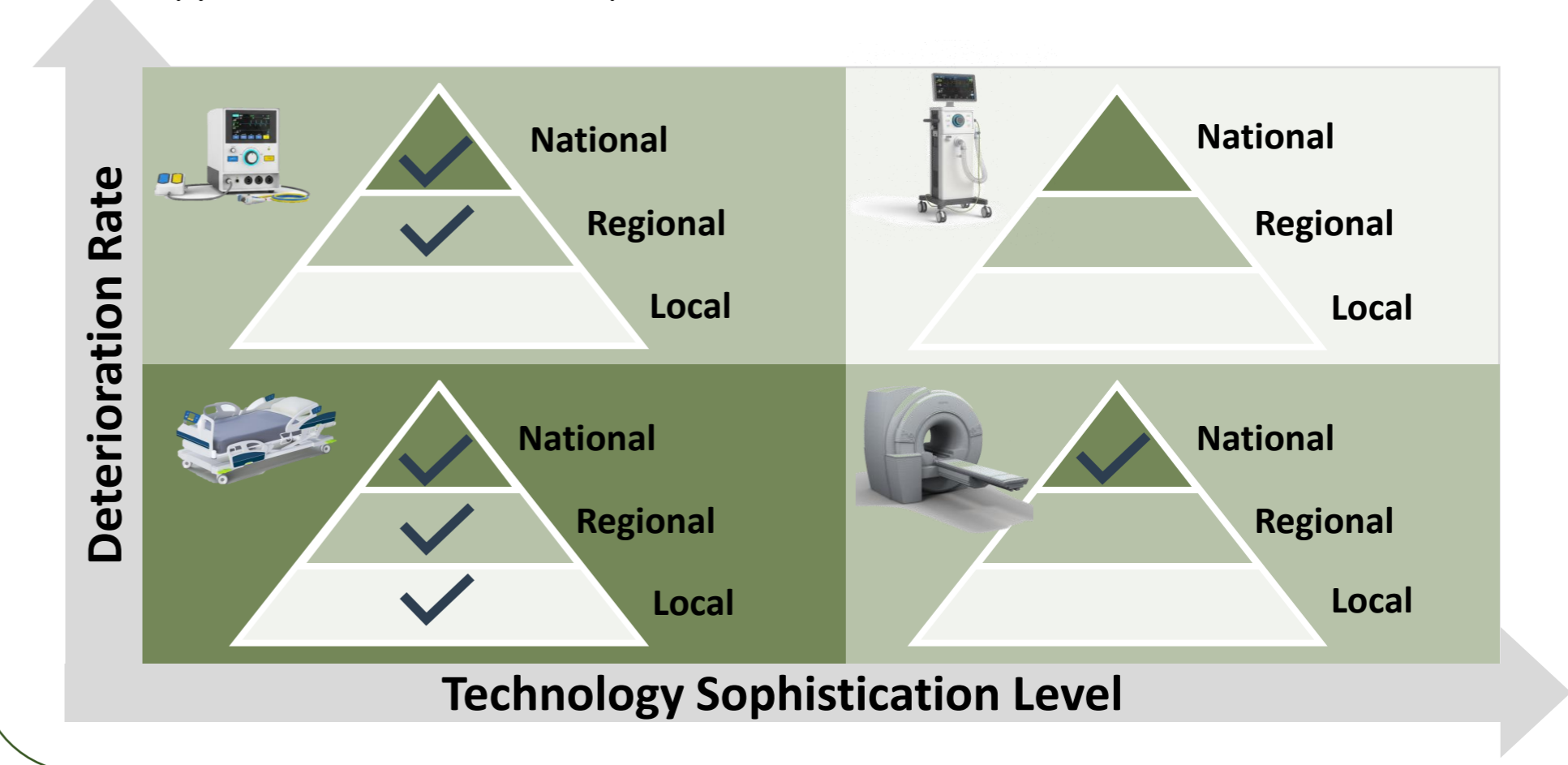

RTL Numerical Evaluation³

Analytical results confirm RTL's dominance across all metrics.

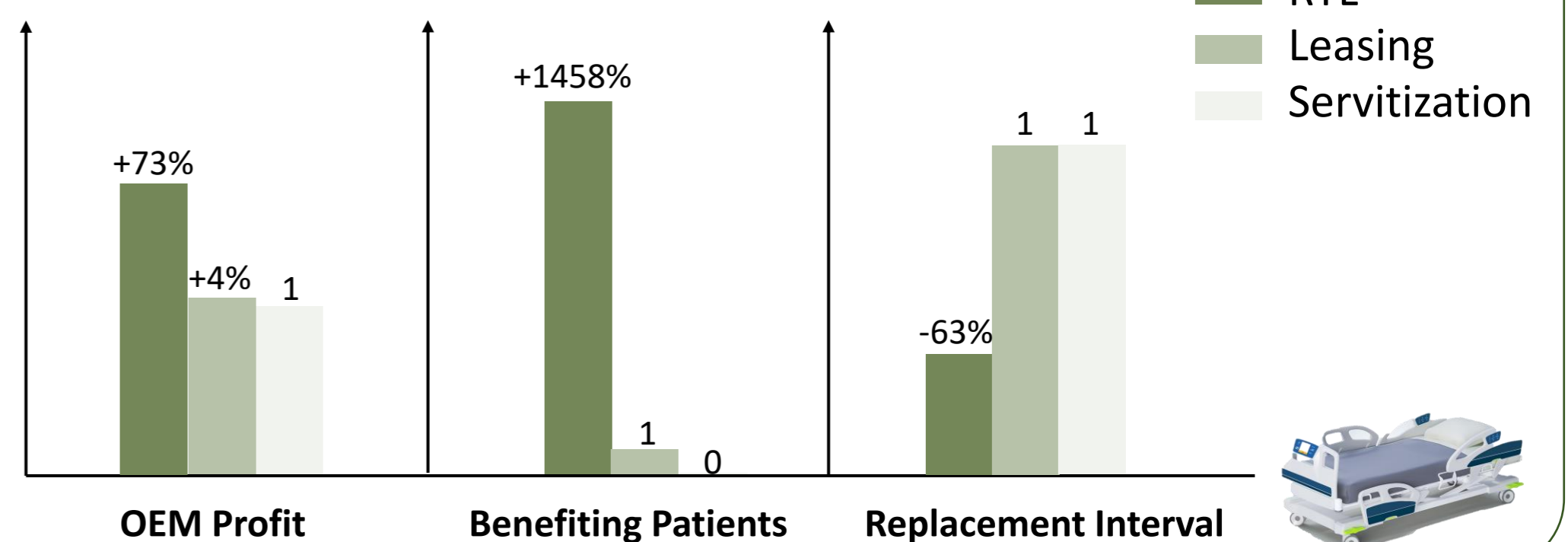

¹ Magnetic resonance imaging (MRI) units | OECD (2023)

² Ogbole, G. I., et al.(2018). Survey of magnetic resonance imaging availability in West Africa. *The Pan African Medical Journal*, 30, 240.

³ Based on simulation data

INTEGRATING LIFE CYCLE ASSESSMENT INTO SUPPLY CHAIN DECISIONS



Selin Hülagü, Wout Dullaert, A. Sena Eruguz, Reinout Heijungs, Dirk Inghels
Vrije Universiteit Amsterdam



INTRODUCTION

Life cycle impacts of a product depend on the supply chain (SC) structure

Good decision relies on good measurement

SCO (Supply Chain Optimization)

Optimizes network decisions to deliver products efficiently and sustainably

LCA (Life Cycle Assessment)

Established, standardized method to measure environmental impacts

LITERATURE

SCO and LCA are treated as separate, sequential steps

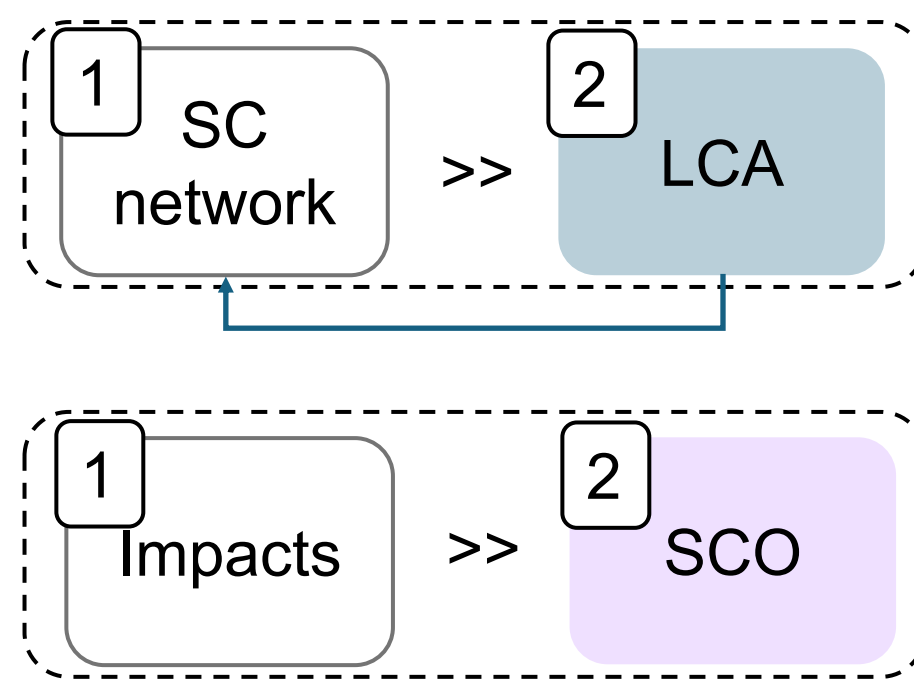

OBJECTIVE

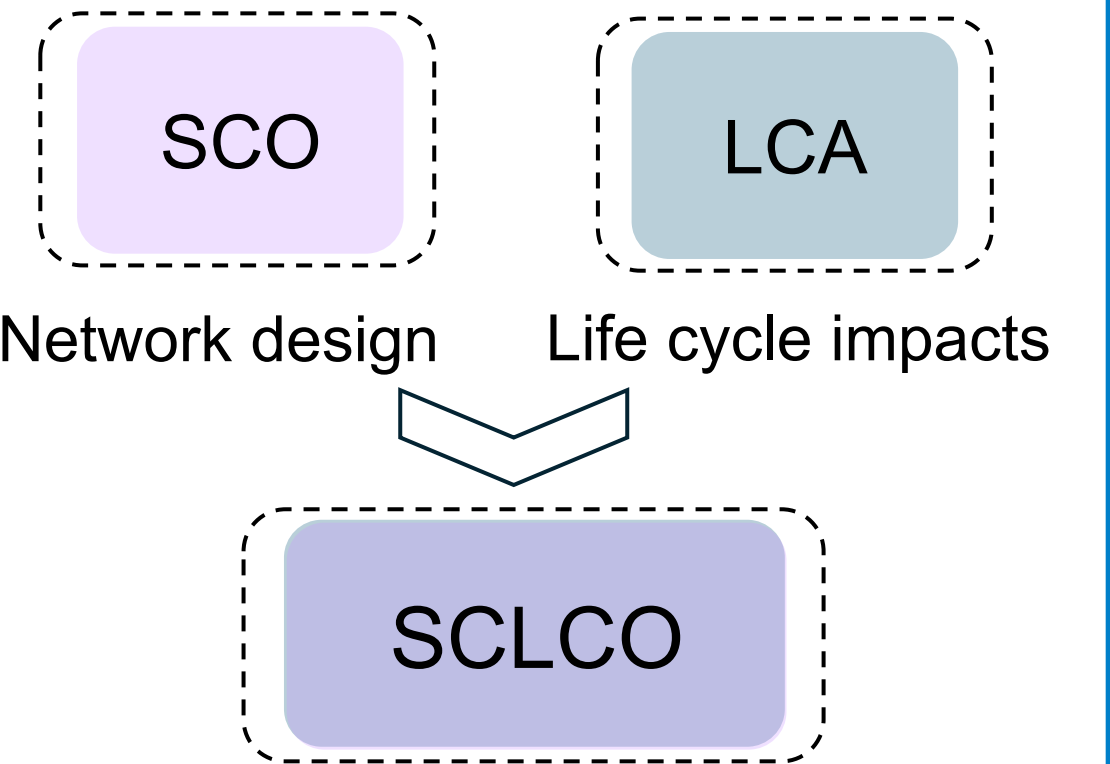

SCLCO MODEL

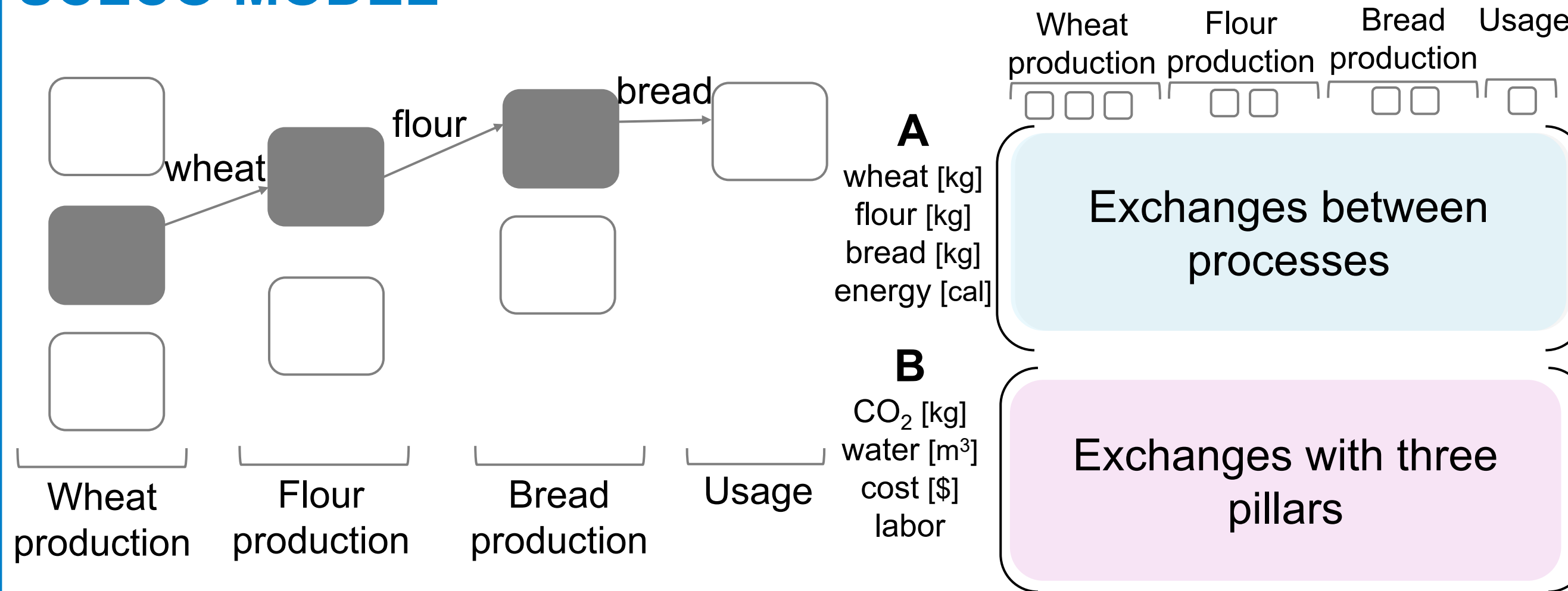

Adopts LCA matrix-based representation

Defines the system by **A, B** matrices
Decisions are **Scaling Vectors** (how much a process is performed)

MILP formulation for multi-product, multi-period closed-loop supply chain

All key aspects and steps of LCA are part of the optimization

CONTRIBUTIONS

Efficiency Streamlines data transfer from LCA databases directly into SC planning

Communication Provides a "common language" for LCA and SCO experts

Transparency Minimizes the risk of overlooking the impacts of decisions

Compliance with (upcoming) EU environmental directives and mandatory corporate reporting

VALIDATION

Yielded the exact same results as traditional SCO models, validating the formulation

Contribution analysis identified hot spots

Adding "overlooked" LCA data (storage) shifted the environmentally optimal solution, raising resulting costs by 20%

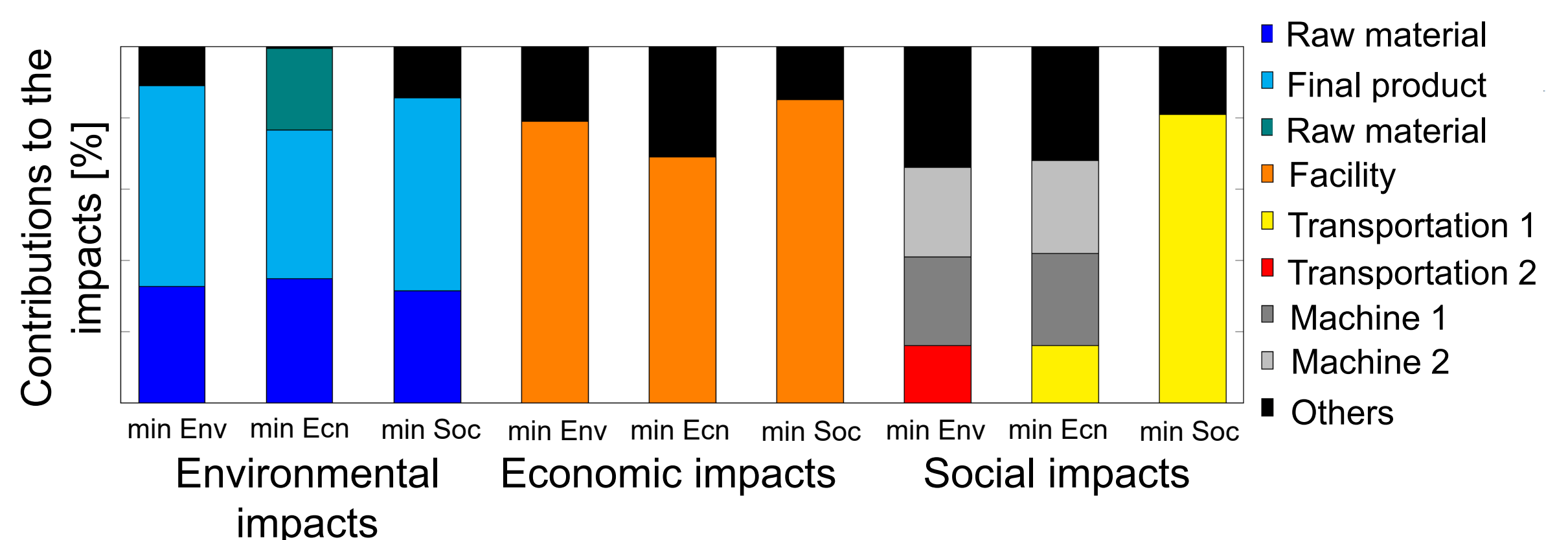

REAL WORLD APPLICATION

Energy-intensive metal supply chain (+200 products, +2000 orders).

Decisions: Supplier selection, production routing, energy sources, and inventory

Objective: Multi-objective optimization (Carbon Footprint vs. Costs)

Minimizing emissions requires relocating upstream production, increasing storage, and adopting green energy

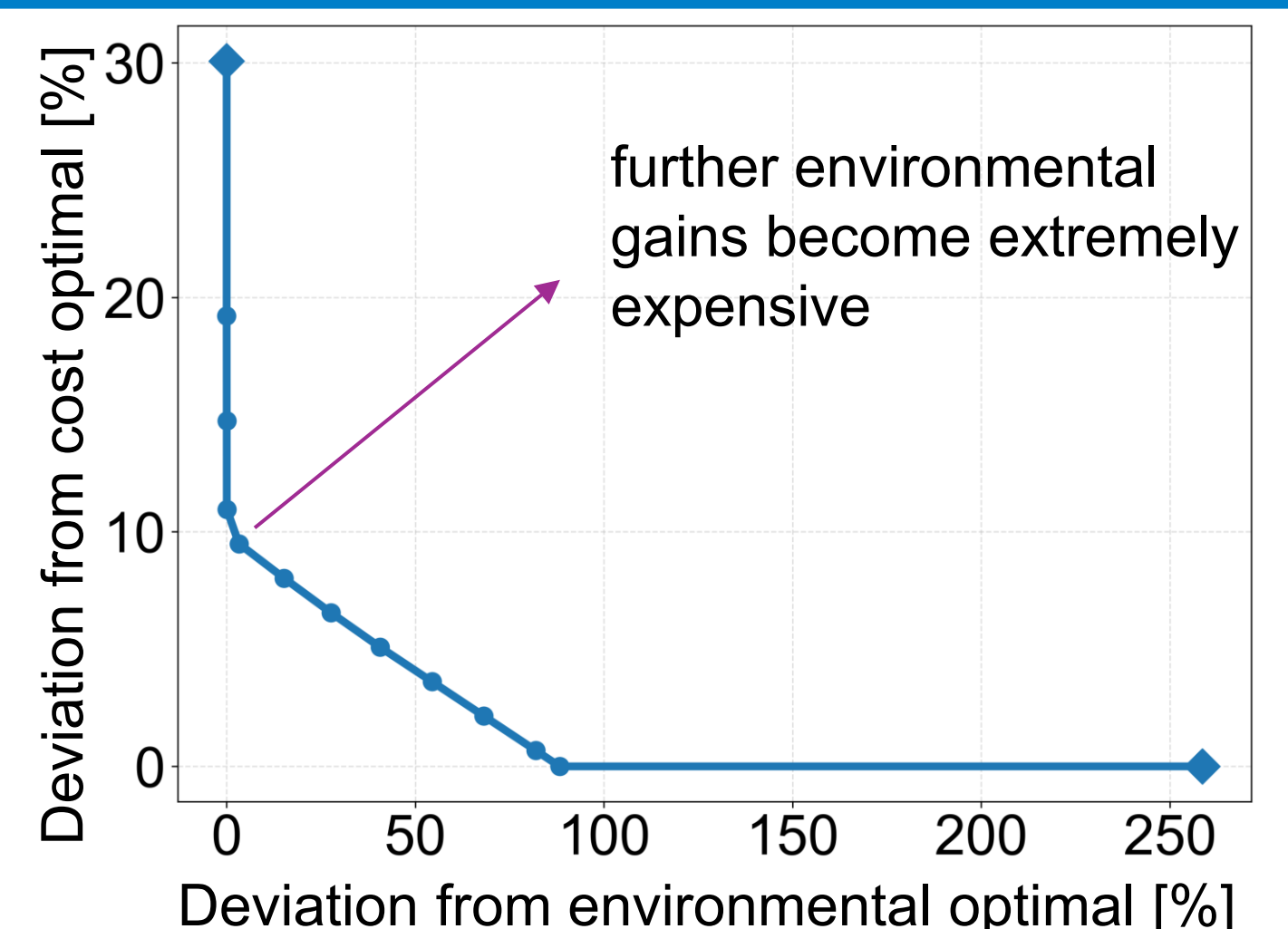

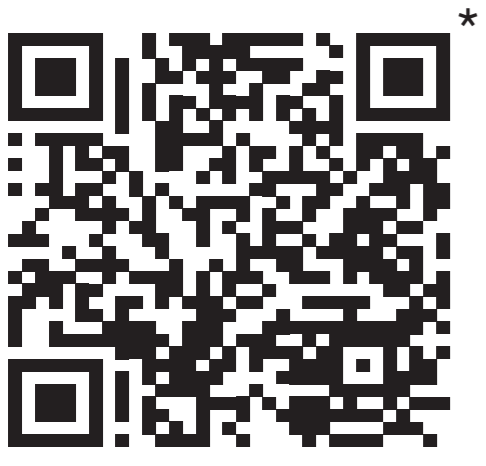

The Effect of AI Communication Style on Human Reliance Under Task Complexity

A. Nasiri*, G. van Kollenburg, C. Snijders, R. Basten



Image is generated by OpenAI's ChatGPT 4o

Tagline

Industry 5.0 envisions humans and AI working together toward sustainable manufacturing — but for that collaboration to work, humans need to know when to trust AI advice. This research asks:
Does the way AI communicates change how much we rely on it?

Background

Optimizing industrial processes is key to reducing energy waste and supporting circular production systems. AI-driven optimization tools can recommend near-optimal settings, yet their value depends entirely on whether human operators actually follow their advice.

Research Question

Does the communication style of an AI recommendation — imperative vs. suggestive phrasing — influence how much human operators rely on it, and does this effect depend on task complexity?

We distinguish between how confident AI sounds (tone/style) and explicit numerical confidence (X% Confident), focusing on the former as an understudied but highly practical lever.

Study Design

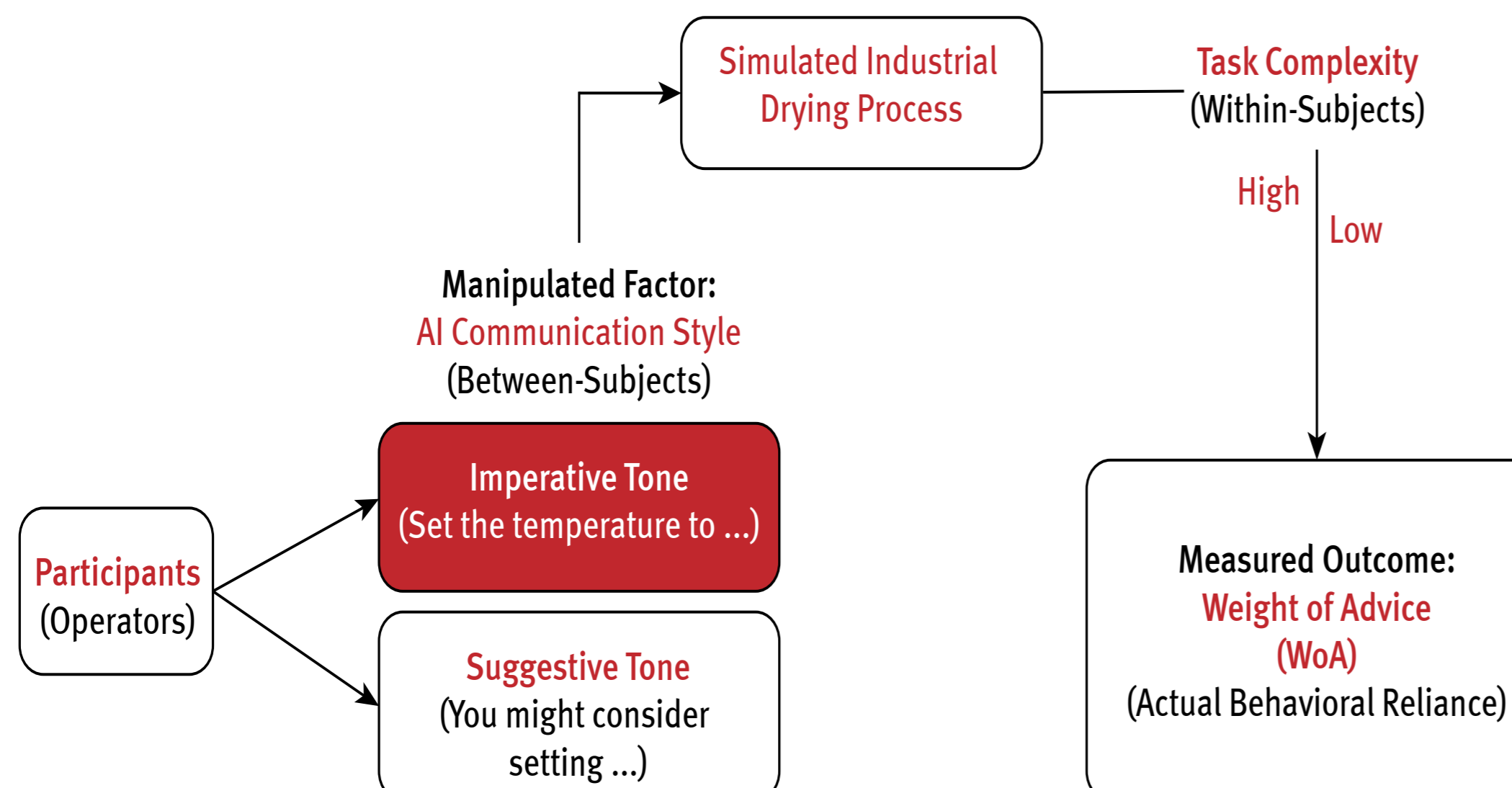

What's Next

The main experiment is currently underway. We are collecting behavioral reliance data across both tone conditions and complexity levels, with analysis planned for Spring 2026.

We are also exploring perceived AI confidence as a mediating mechanism linking communication style to reliance behavior.

Why This Matters for Sustainability

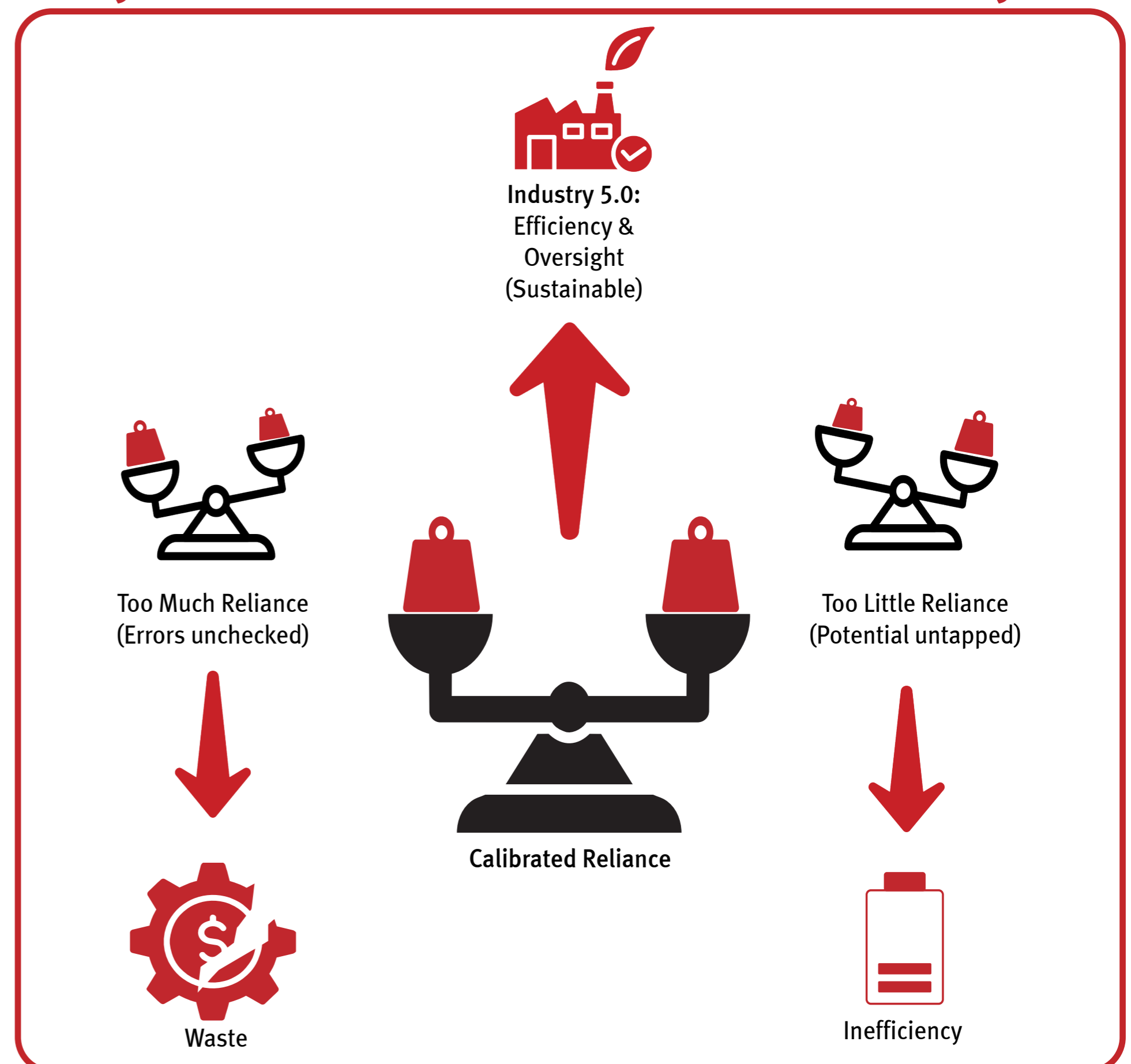

Let's Talk

- How do you think operators in your domain respond to AI communication?
- What role does trust calibration play in the circular/sustainable systems you work?
- Interested in cross-disciplinary collaboration on human–AI interaction in industrial settings?

Aran Nasiri
Department of IE & IS, TU/e
OPAC Group | HTI Group
a.nasiri@tue.nl

Energy Management in Hubs for Circularity using a Modular Network Representation

Tobias Løvebakke Nielsen, D. Guericke, A. Trivella & DM. Yazan
BMS-HBE-IEMS

UNIVERSITY OF TWENTE.



Introduction

To transition into a circular economy future, both renewable energy and waste sharing through industrial symbiosis is needed. However, how they operationally complement each other is a relatively new research field, and the current research primarily focusses on case study-tailored model structures. We propose a stochastic generic modular network structure based on linear programming, making it applicable for various kind of case studies.

Objective

To investigate the operational synergy between industrial symbiosis and renewable energy supply

Modular Building Blocks

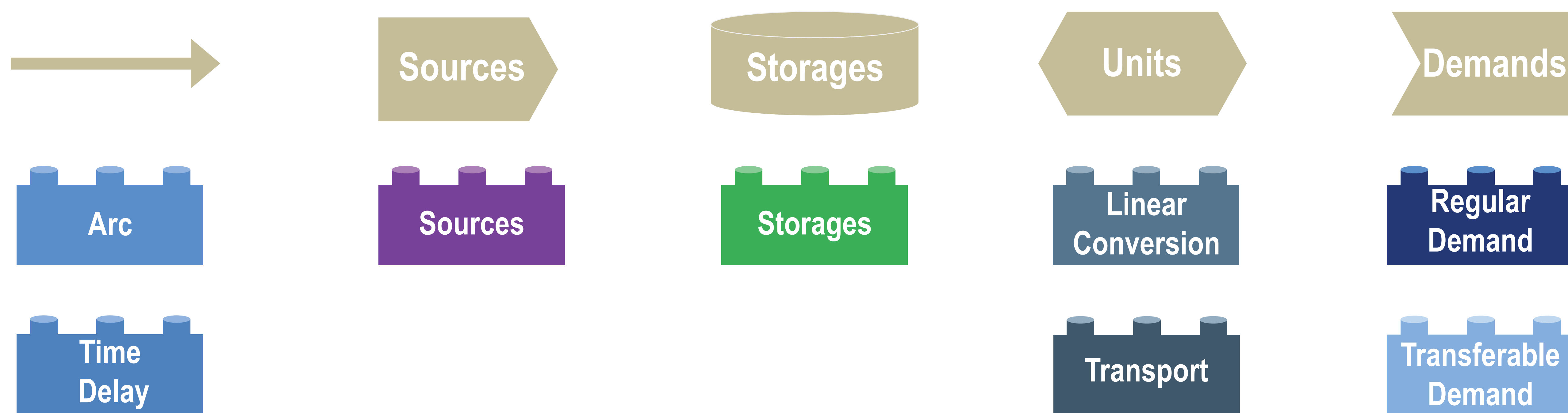

Network Structure

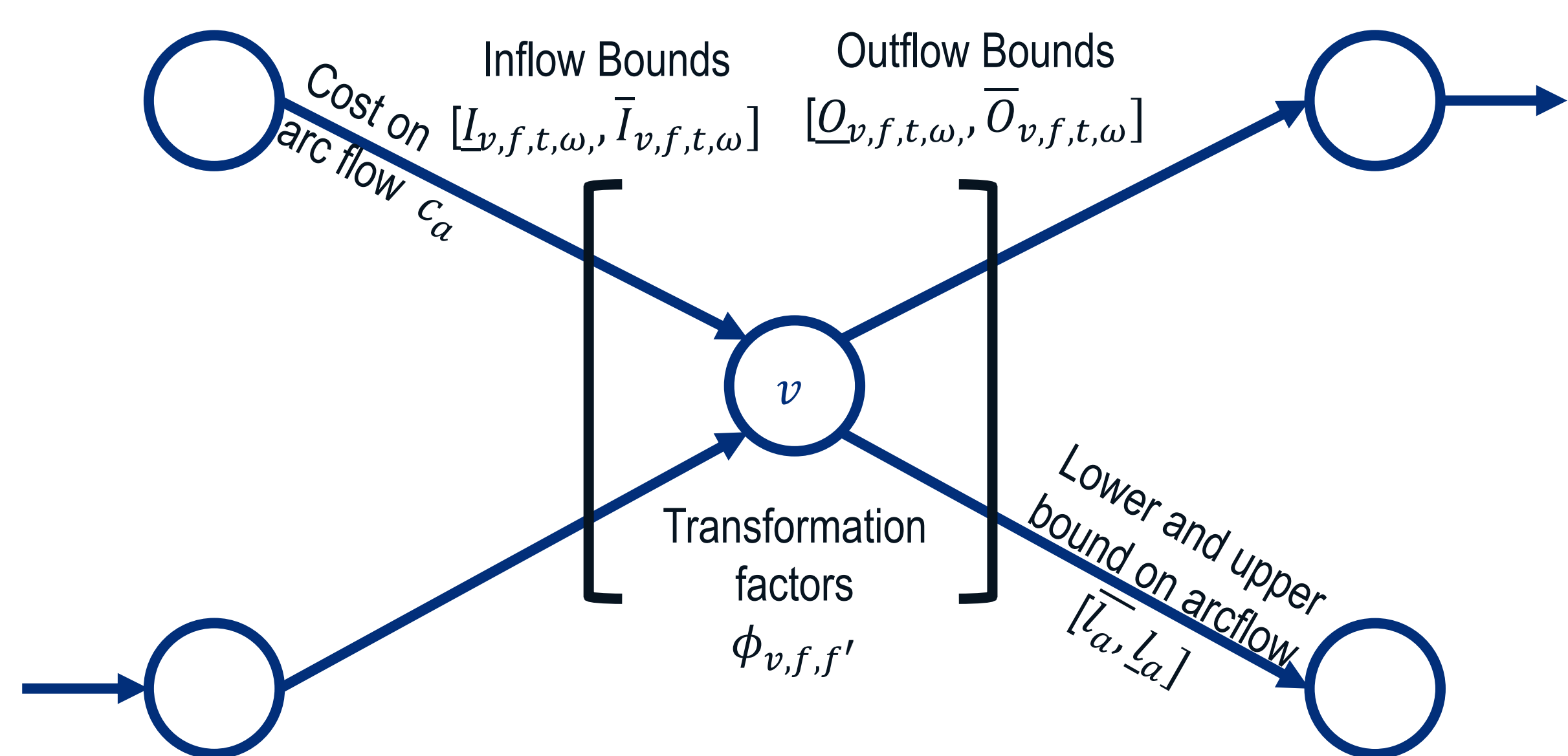

Case Study

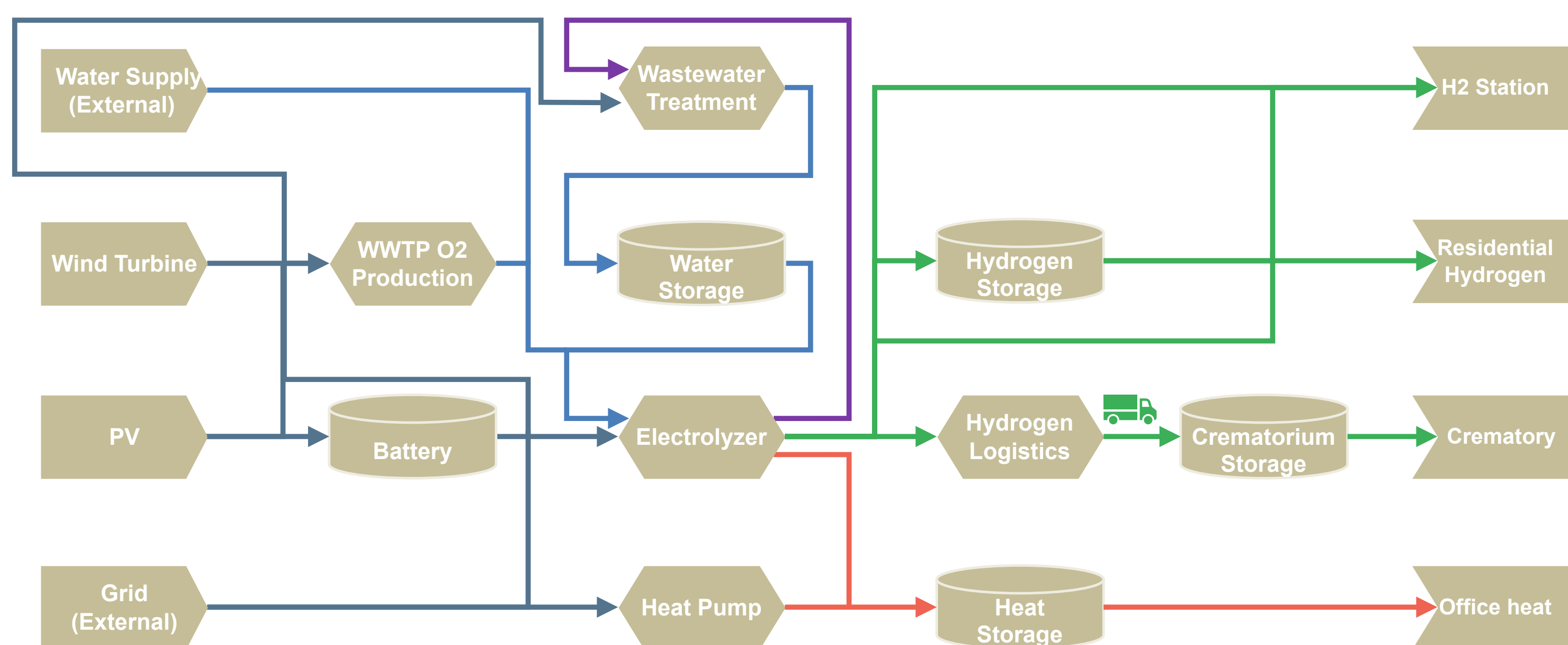

Results

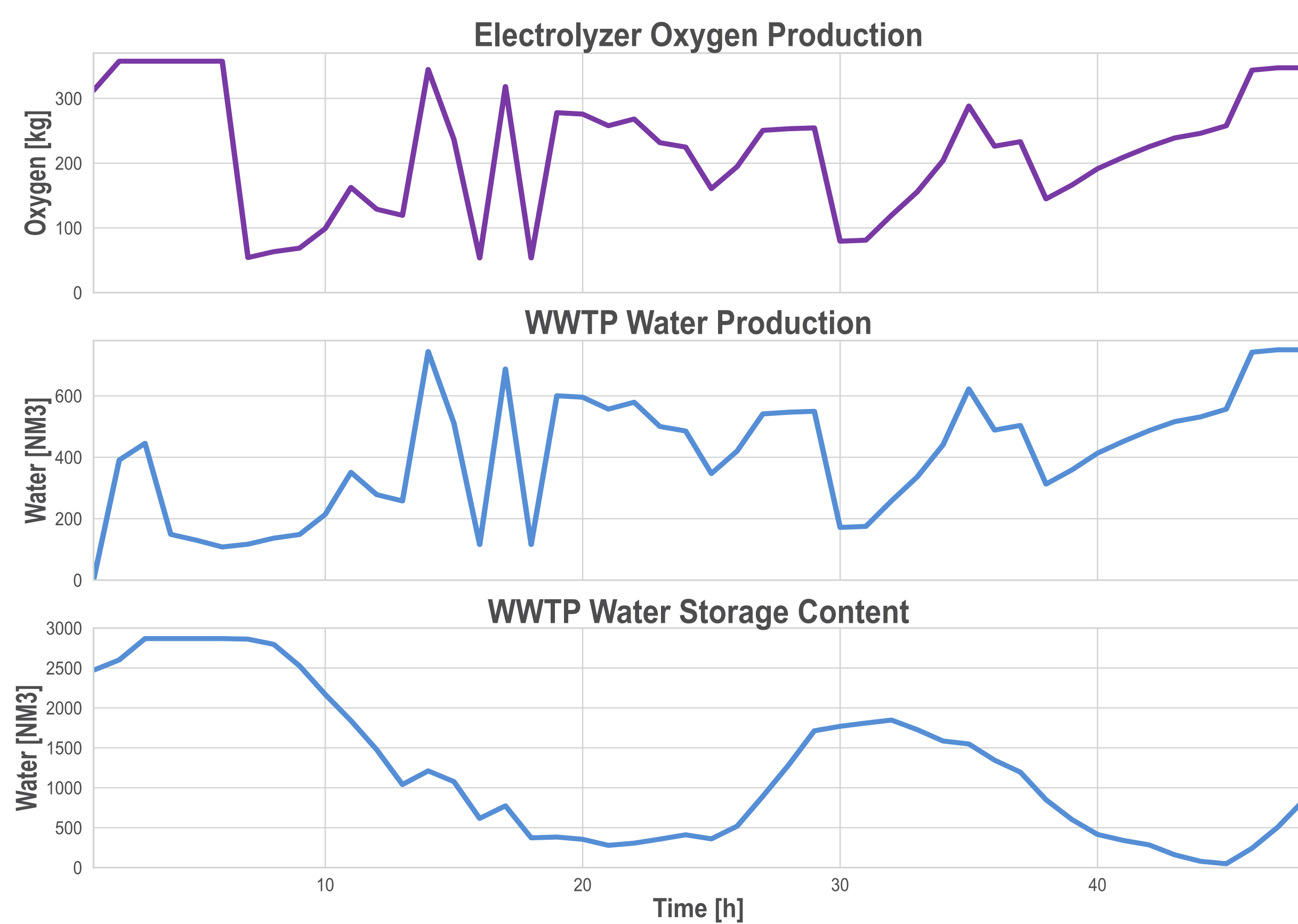
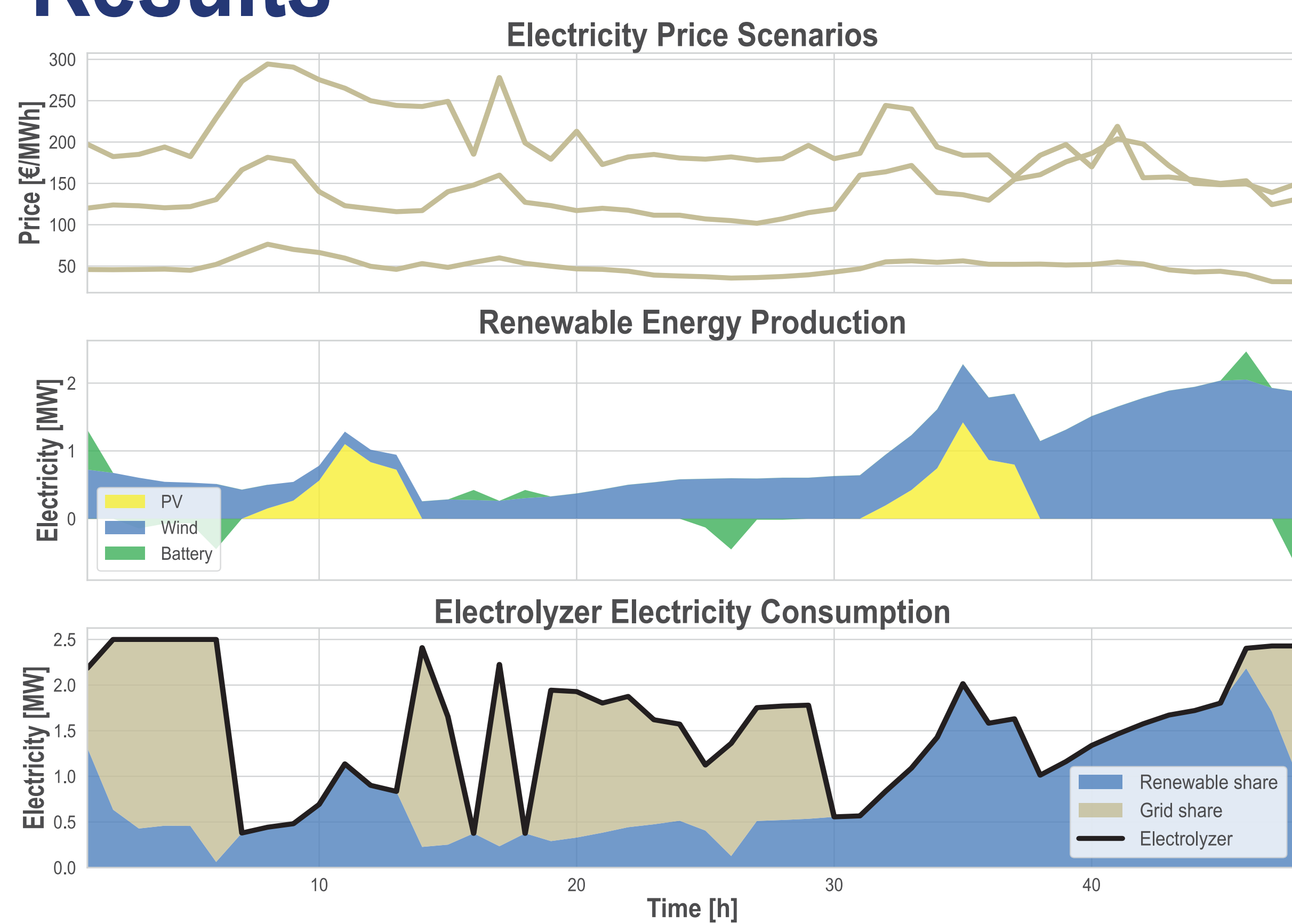

Discussion

- Considering a 30 day period, the industrial symbiosis and renewable synergy reduced operational cost by 7.9%
- Flexible storages facilitate industrial symbiosis operation

Further work:

- Extend modular representation to be applicable for a larger range of cases
- Analyse the synergies across different seasons



This project has received funding from the European Union's HORIZON Research and Innovation Actions programme under grant agreement number 101138473



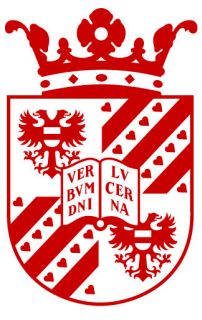

university of
 groningen

Designing Multi-Actor Governance and Coordination for AM-Based Circular Networks

Juno Joseph Ninan, dr. Dirk Pieter van Donk, dr. Eugenia Rosca
 Faculty of Business and Economics, University of Groningen

Introduction

Despite extensive research on circular economy (CE), real-world implementation remains limited, and many studies are conceptual with few empirical examples. Achieving a functional CE requires moving from focal firms in linear chains to multi-actor networks. However, network-level governance and collaboration mechanisms remain underexplored. While Additive Manufacturing (AM) plays a key role in enabling CE, it introduces further challenges like intellectual property (IP) protection, stakeholder trust and path dependency.

Objective

To identify design principles for governance and coordination of circular supply networks using AM for repair or remanufacturing of spare parts

Initial Mapping (Empirical Studies)

<p>Swedish Steel Recycling (Berlin et al., 2022)</p>	<ul style="list-style-type: none"> • Network Type: Vertical & Lateral • Key Governance & Collaboration Mechanisms: Formal standards, procurement committee, joint ownership, quality audits • Insight: Network level coordination relies on formal structures; power balances & relational trust affect collaboration
<p>Circular Textile Supply Chain (Saccani et al., 2022)</p>	<ul style="list-style-type: none"> • Network Type: Vertical & Horizontal • Key Governance & Collaboration Mechanisms: Long-term contracts, equity participation, vertical integration, digital traceability, co-design, financial support • Insight: Upstream actors drive orchestration; institutional support and digital tools are crucial

To what extent can mechanisms from such empirical cases be applied or adapted to AM-based networks considering their unique governance challenges around IP and trust?

Research Roadmap

Systematic Literature Review: Mapping governance & collaboration mechanisms in circular networks and supply chains to identify relevance for AM networks

Case Study Research: Investigating real-life circular chains to inform AM network design

Multi-Panel Delphi: Gathering perspectives from diverse stakeholder groups on conflicts, constraints and enablers for effective governance

Design Science: Developing design principles & governance frameworks for AM-based circular networks and co-creating them with consortium partners

Expected Outcomes

- Benchmarking insights from existing circular supply chains and networks
- Validated design principles for governance of AM-based networks
- Guidelines for AM network implementation



Scan for References

Additive Manufacturing in Circular Economy

A Metal End-of-Life Decision Model

Ozgur Oskay & Mehrdad Mohammadi

Research Problem

With increasing material criticality and regulations, metal end-of-life (EOL) management plays a central role in the circular transition. Even though additive manufacturing (AM) is a key technology supporting metal circular practices, its economic viability remains uncertain across different EOL strategies. This study addresses this gap by:

- Investigating when AM is more cost-effective than subtractive manufacturing (SM) for different reuse options.
- Developing a decision model to support the selection of appropriate recovery strategies.

EOL Pathways with AM

EOL products have several pathways with different depth and required effort [1]. AM supports several ones, displayed in grey [2].

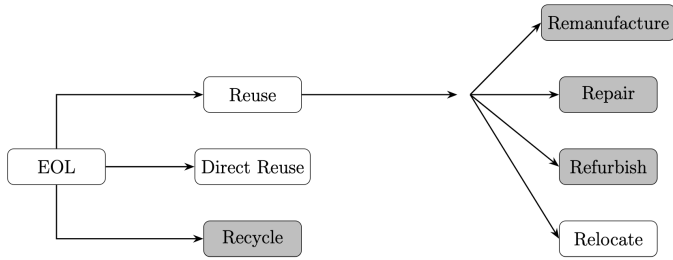

Figure 1: End-of-life pathways.

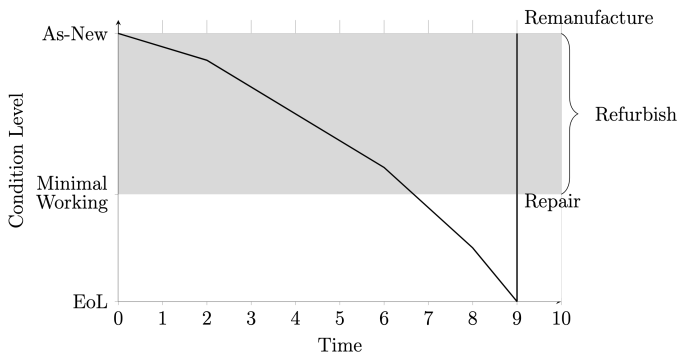

Figure 2: Reuse options as condition levels.

References

- [1] M. Thierry, M. Salomon, J. van Nunen, and L. van Wassenhove, "Strategic issues in product recovery management," *California Management Review*, vol. 37, no. 2, pp. 114–136, 1995.
- [2] A. Saboori, A. Aversa, G. Marchese, S. Biamino, M. Lombardi, and P. Fino, "Application of directed energy deposition-based additive manufacturing in repair," *Applied Sciences*, vol. 9, no. 16, art. 3316, 2019.
- [3] S. Panagou, G. La Cava, F. Fruggiero, and F. Mancusi, "Selective complexity determination at cost based alternatives to re-manufacture," in *IFIP International Conference on Advances in Production Management Systems*, pp. 215–228, 2023.

Parametric Analysis

We implement cost functions for the reuse pathway under AM and SM [3]:

$$C_{\text{base}}^{\text{tech}} = C_{\text{material}}^{\text{tech}} + C_{\text{operational}}^{\text{tech}} + C_{\text{processing}}^{\text{tech}} + C_{\text{post}}^{\text{tech}} + C_{\text{energy}}^{\text{tech}}$$

$$C_{\text{reuse}} = \min_{\text{tech} \in \{\text{AM}, \text{SM}\}} \{C_{\text{base}}^{\text{tech}}(1 + (1 - RPR))(1 + \Delta_{\text{cond}})\}$$

RPR : Relative Product Recyclability, $\Delta_{\text{cond}} = \kappa_{\text{des}} - \kappa_{\text{cur}}$

We show that **complexity**, the effects of **batching** and **volume** are critical for choosing the right technology.

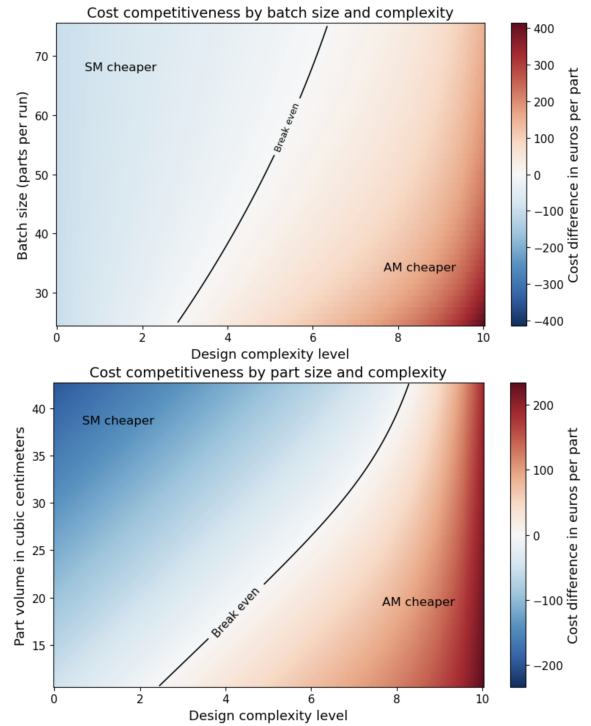

Figure 3: Parametric analysis of reuse operations.

Decision Model

We construct value functions for each EOL pathway based on economic and operational parameters.

Reuse $V_{\text{reuse}} = \max_{\kappa_{\text{des}}} \{P_{\text{reuse}}(\mathbf{x}, \kappa_{\text{des}}) - C_{\text{reuse}}(\mathbf{x}, \kappa_{\text{cur}}, \kappa_{\text{des}})\}$

Direct reuse $V_{\text{direct}} = P_{\text{base}} e^{-\lambda(1-\kappa_{\text{cur}})}$

Recycling $V_{\text{rec}} = \max\{P_{\text{rec}}^{\text{SM}}(\mathbf{x}, \kappa_{\text{cur}}), P_{\text{rec}}^{\text{AM}}(\mathbf{x}, \kappa_{\text{cur}}) - C_p\} - C_{\text{rec}}(\mathbf{x}, \kappa_{\text{cur}})$

The optimal EOL pathway of product \mathbf{x} is:

$$\arg \max_{\text{path} \in \mathcal{P}} v_{\text{path}}(\mathbf{x}, \kappa_{\text{cur}})$$

Analysing Misalignments to Improve Circularity in Modular Construction Manufacturing

G.K. Ramana Moorthy, C.Fecarotti, J.B.F. Ivo Adan

Circularity in Modular Construction

Modular construction enables standardisation, disassembly, and reuse, but these circular potentials remain under-realised as CE principles seldom guide real design and production decisions.

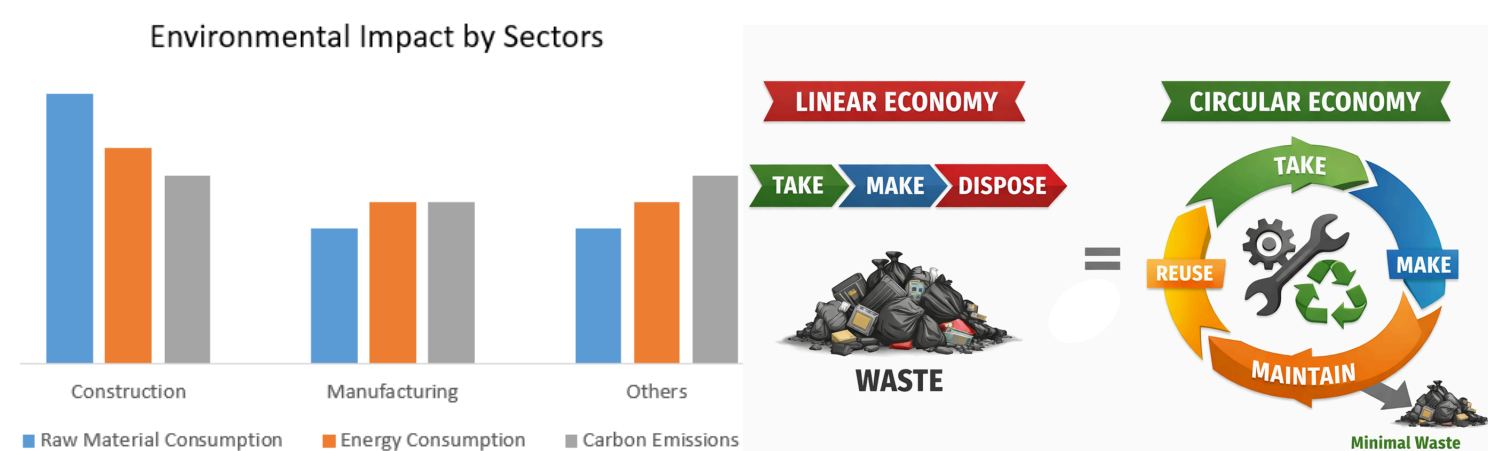

Construction is the largest contributor CE aims to Retain Material Value Longer

- Circularity lacks a shared interpretation across supply chains, leading to fragmented and siloed operations.
- Lack of strategic and operational translation of abstract CE principles creates a gap in execution.

Operationalizing Circularity in MC

Academic and institutional research has consolidated CE into **six core principles** that aim to implement circularity.

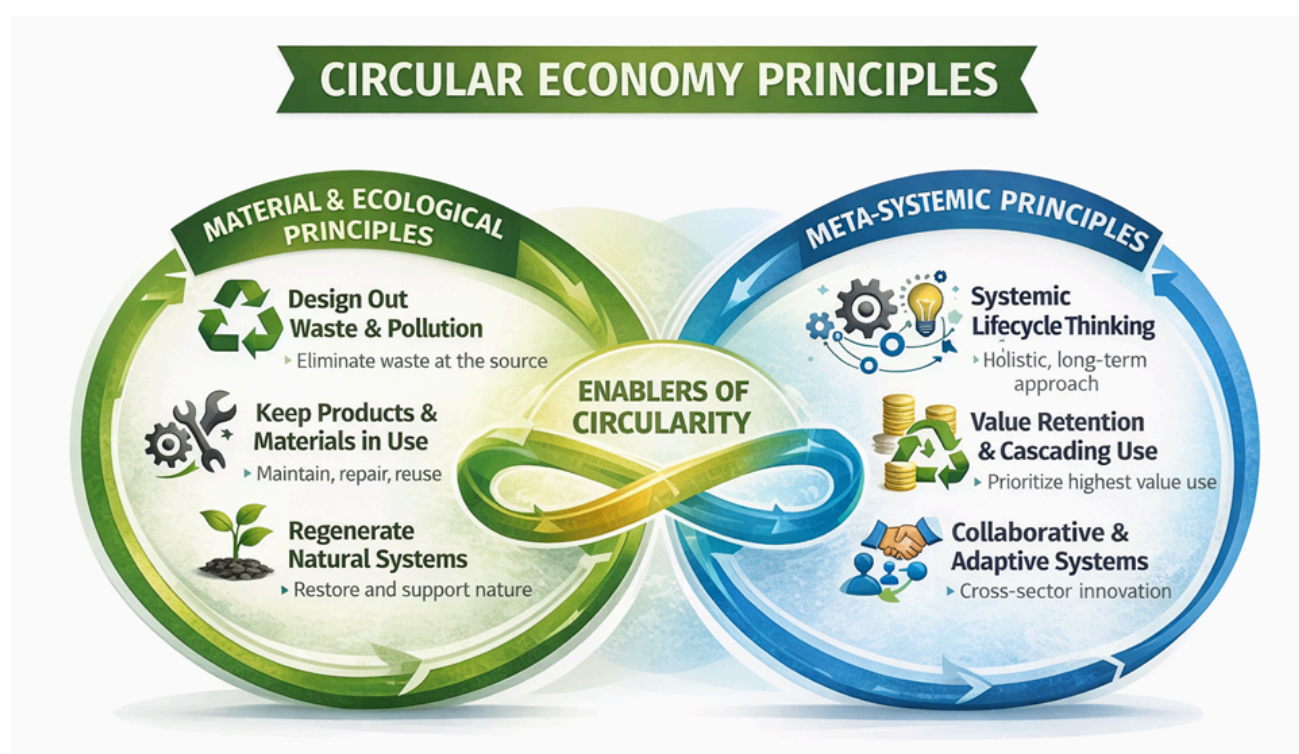

- R-strategies act as the functional layer that translates CE principles into actionable interventions across modular construction lifecycles.
- We translate these strategies into practice by identifying key enablers (CSFs) and measuring them through KPIs across product, process, and organizational domains.

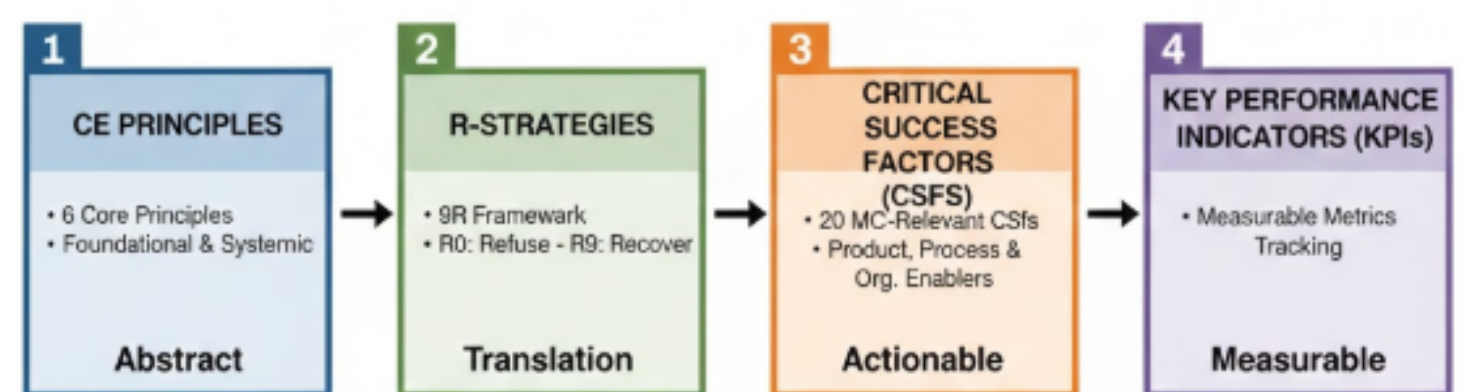
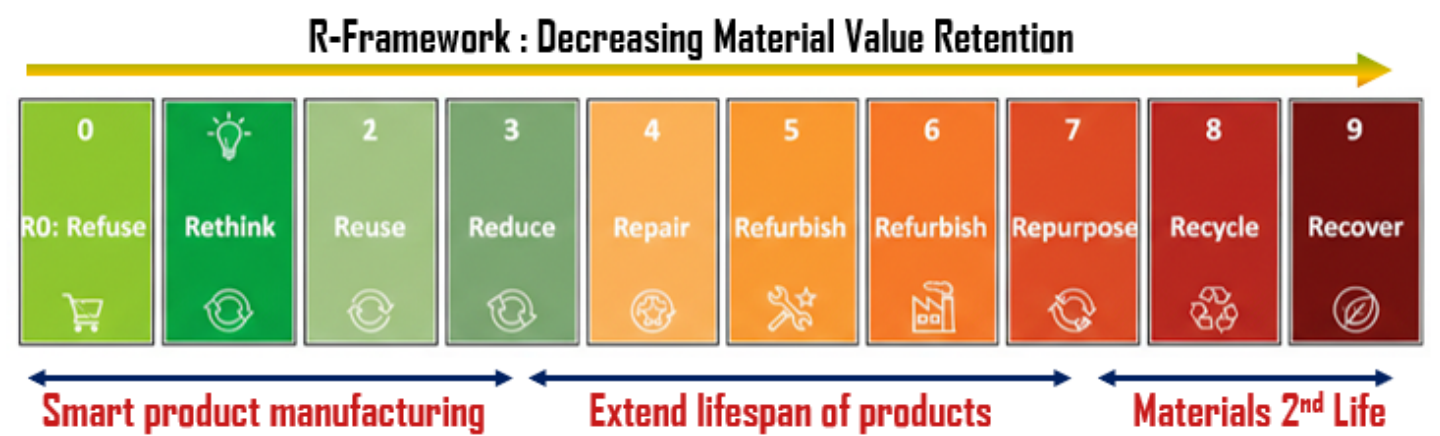

- Constructing an Multi-Domain Matrix to map product–process–organization links to identify dependencies, reveals which elements are most critical in the system.

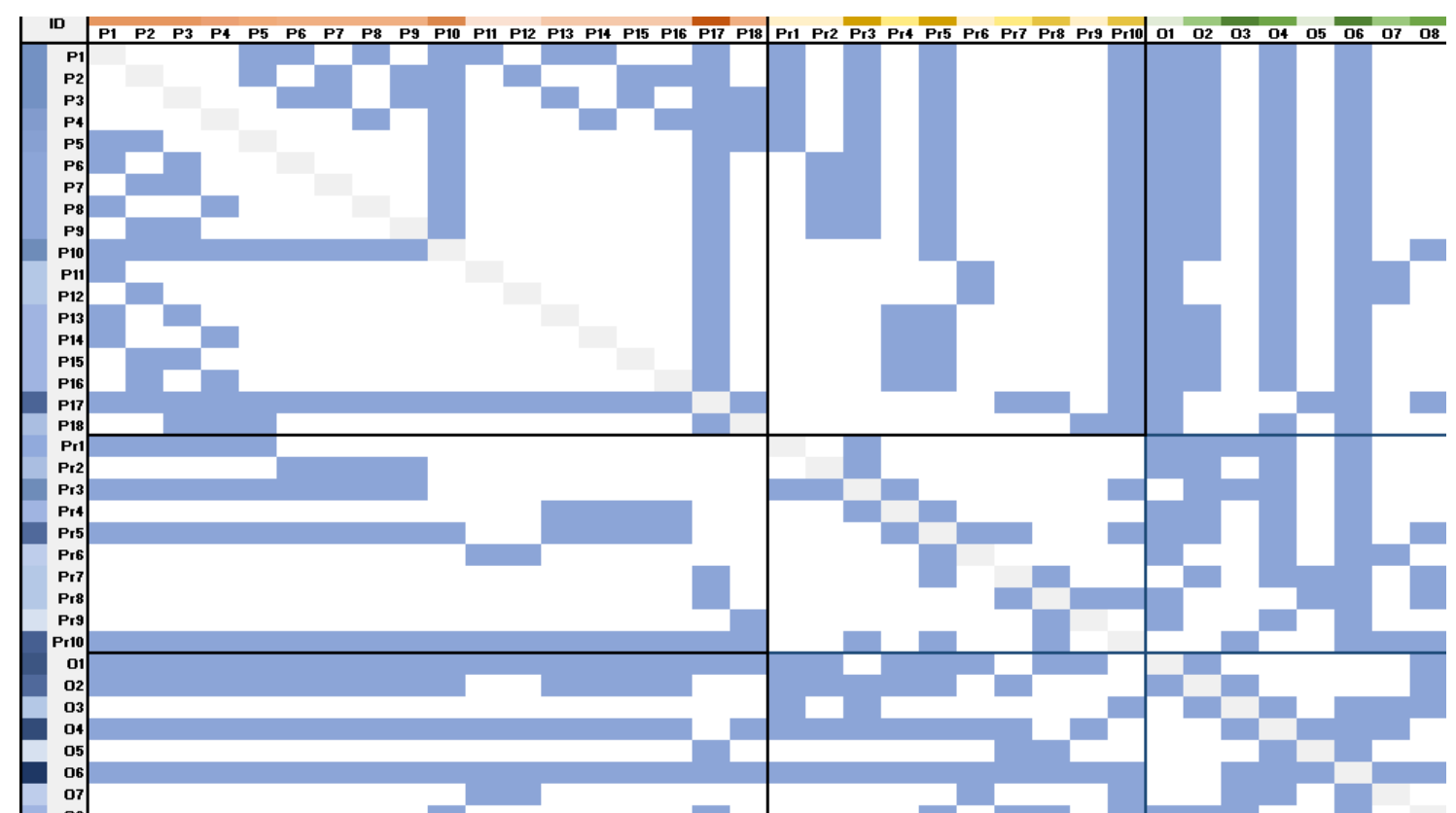

Structural Matrix Representing Dependencies & Centralities

- KPIs are assigned and scored on each dependency forming a performance matrix, exposing where structural connections fail to support circularity.

Expected Outcomes

Three types of misalignment emerge:

- Structural–Performance Misalignment
- Dependency Asymmetry
- Overreliance on Downstream Strategies

These insights reveal where circularity breaks and indicate which CE principles need stronger operational support.

Transition to the circular economy through digital innovation: the DICE mechanism architecture

Meisam Ranjbari¹, Zahra Shams Esfandabadi², Francesco Quatraro¹

¹ University of Turin, Italy

² Eindhoven University of Technology, the Netherlands

Emails: meisam.ranjbari@unito.it, z.shams.esfandabadi@tue.nl

Research Motivation

Digital innovation (DI) is increasingly positioned as a strategic enabler of circular economy (CE) transitions, yet existing scholarship remains conceptually fragmented and theoretically underdeveloped, particularly regarding how DI shapes CE transition trajectories. This study develops an integrated, theoretically grounded, and empirically refined framework, hereafter referred to as the DICE configurational mechanism architecture, which addresses the following research questions:

- **RQ1:** *How and through what mechanisms does DI shape CE transitions?*
- **RQ2:** *Through what configurations of mechanisms does DI enable the scaling of CE initiatives?*

Two-tiered Research Design

Tier-1: Conceptual model development

- Grounded-theory-informed meta-synthesis
- Inductive coding of 107 studies (open, axial, and selective coding)

Tier-2: Configurational empirical analysis (ongoing)

- Fuzzy-set qualitative comparative analysis (fsQCA)
- Analysis of 48 DI-enabled CE initiatives

Tier-1 results: DI and the CE transition: A stratified mechanism architecture

The results conceptualizes DI–CE mechanisms as:

recurrent, empirically observable patterns of action with causal relevance through which DI enables, reconfigures, embeds, amplifies, or conditions CE transition processes. They capture an analytically distinct yet interrelated pattern of action that links digital activities to observable effects in circular systems in contingent and context-dependent ways.

The developed architecture organizes nine DI–CE mechanisms into six macro-causal layers:

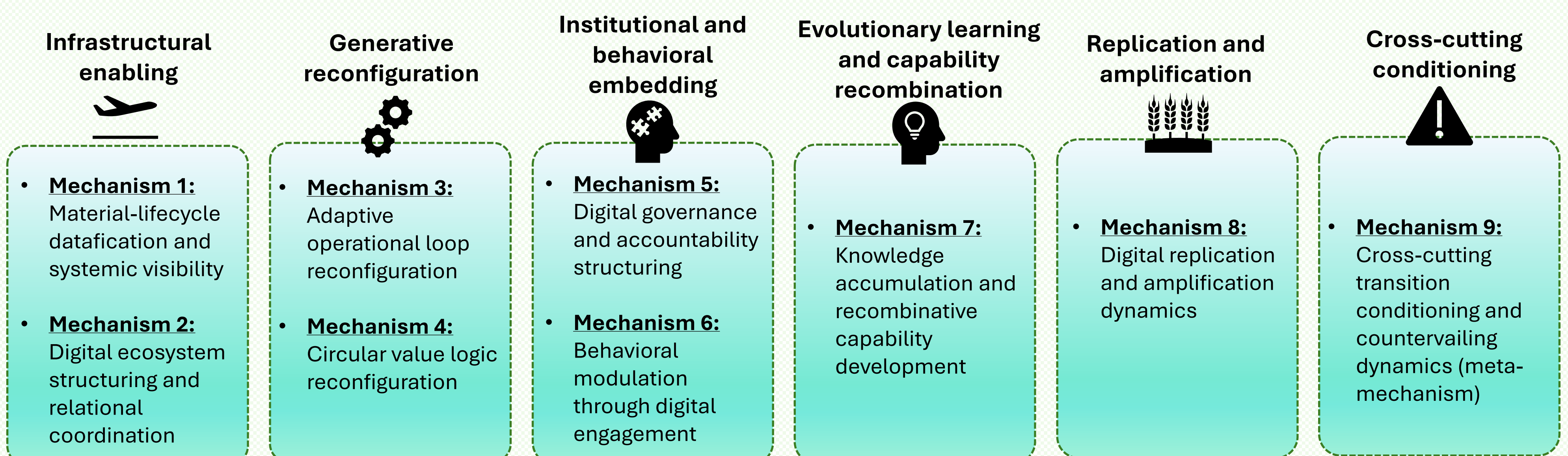

Core proposition

DI shapes CE transitions through a stratified and configurational architecture of analytically differentiated yet interdependent mechanisms that function as:

- infrastructural enablers establishing epistemic visibility and relational coordination (M1–M2);
 - generative drivers reconfiguring operational loops and circular value logics (M3–M4);
 - institutional-behavioral stabilizers embedding durable participation structures (M5–M6);
 - recursive capability evolvers advancing adaptive capabilities through knowledge recombination (M7); and
 - scaling amplifiers extending circular configurations through network-based replication (M8);
- the activation and effects of this architecture remain contingent on cross-cutting transition conditioning and countervailing dynamics (M9).

Tier-2 results (ongoing):

Tier-2 empirically examines how the mechanisms identified in Tier-1 combine in different configurations to generate varying degrees of CE outcomes in practice, which is considered as the scaling of DI-enabled CE initiatives: defined as the extent to which circular initiatives extend beyond pilot implementation and achieve sustained expansion and institutional embedment.

- Necessity and sufficiency analyses
- Core and peripheral DI–CE mechanisms within each configuration
- DI–CE pathways

Implications

For Theory

Provides the first mechanism-configurational architecture linking DI to CE transitions. This architecture shifts the focus from “which technologies enable circularity” towards “how digitally enabled mechanisms collectively structure the pathways of CE transitions.”

For Practice

Identifies where digital interventions matter most across different stages of CE transitions.



System Dynamics-based Viability Analysis of Collaborative Business Models^{1, 2}

1. Wijnands, B., Rettab, Y., Turetken, O., Ozkan, B., & Tsilionis, K. (2025). A Method for the Viability Analysis of Value Capture in Collaborative Business Models Through System Dynamics. LNCS, 16079, 161–173. <https://doi.org/10.1007/978-3-032-06164-5>
2. Elenbaas, J.J., Rettab, Y., Turetken, O., Tsilionis, K., de Kinderen, S. (n.d.). A Reference Business Model and System Dynamics-Based Viability Analysis for Offshore Green Hydrogen Production (Manuscript submitted for publication; under review).

Problem

A Collaborative Business Model (CBM) defines the value proposed by a network of stakeholders (actors) through a solution to a specific customer, the capabilities they need to deliver that value, and the costs & benefits incurred by each actor. The costs and benefits can be both financial and non-financial. The viability of CBMs depends on whether all actors continue to capture sufficient value over time as the CBM evolves. However, most existing viability evaluation approaches are **static, firm-centric, and qualitative**, limiting the insights they offer into the dynamic interdependencies, interactions, and value exchanges between actors in a CBM. A clear path to parameterizing CBMs for dynamic, quantitative viability simulation is thus missing.

Objective

Develop a structured method to translate CBM value capture (financial and non-financial) into a parameterized System Dynamics (SD) model, enabling multi-actor viability analysis from a network-oriented perspective.

System Dynamics Modeling

A modeling and simulation approach for complex, nonlinear systems (Sterman, 2002).

- Stocks, flows, delays, feedback loops
- Captures implicit assumptions
- Models non-linear, dynamic relationships
- Supports “what-if” scenario analysis

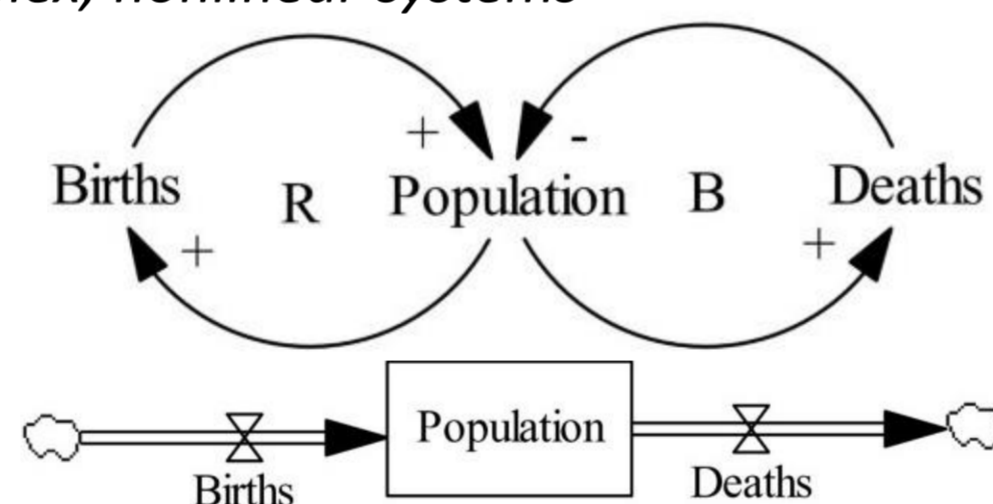

Approach

Design Science Research Methodology (Hevner et al., 2004; Peffers et al., 2007).

Iterative artifact development informed by rigorous evaluation rounds.

- Utility assessed via TAM constructs (usefulness, ease of use, intention to use).

Study 1: Development of the artifact and initial validation in **NGO context**. Participants (N=12): strategy consultants, academics, NGO employees.

Study 2: Extended validation of the artifact in the **green hydrogen context**. Participants (N=15): consultants, academics, policy advisors, mechanical engineer, business developer.

Results

Method Overview

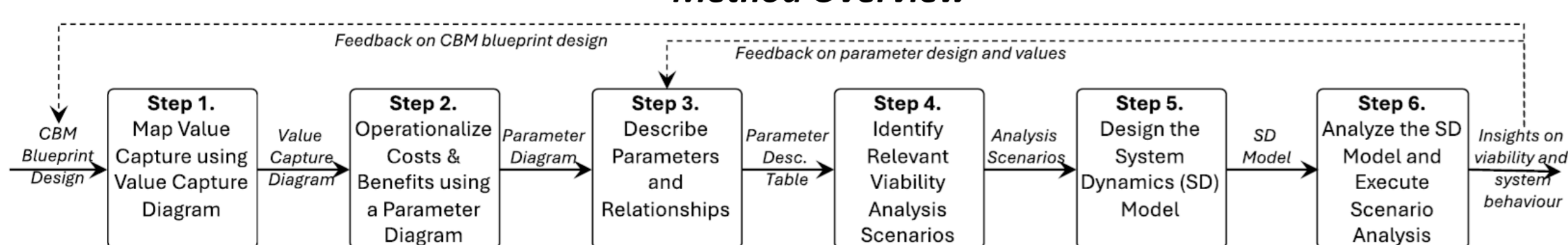

A network-oriented approach that facilitates the translation of financial and non-financial value exchanges into parameters for SD simulation.

- Reveals implicit value-generation opportunities.
- Supports dynamic scenario analysis.

Evaluation Results

- Experts valued the method’s ‘helicopter view’ and ability to make actor interdependencies explicit. Intention to use was high; it supported multi-stakeholder dialogue and discussion. Transparency, clarity and strategic value of the method for scenario analysis was confirmed.
- Concerns:** Need for SD modeling expertise, data quality, scalability and complexity of model as number of actors and parameters grow.

Key Takeaways

Our method offers a structured approach to translate CBM value exchanges (financial + non-financial) into parameters for SD modeling.

- Enables multi-actor viability and scenario analysis
- Makes implicit assumptions and relationships explicit

Application over two contexts + evaluation by diverse experts confirmed the method’s transferability, utility, clarity and transparency.

Practical application may be limited due to required SD expertise and high-quality data + model scalability considerations.

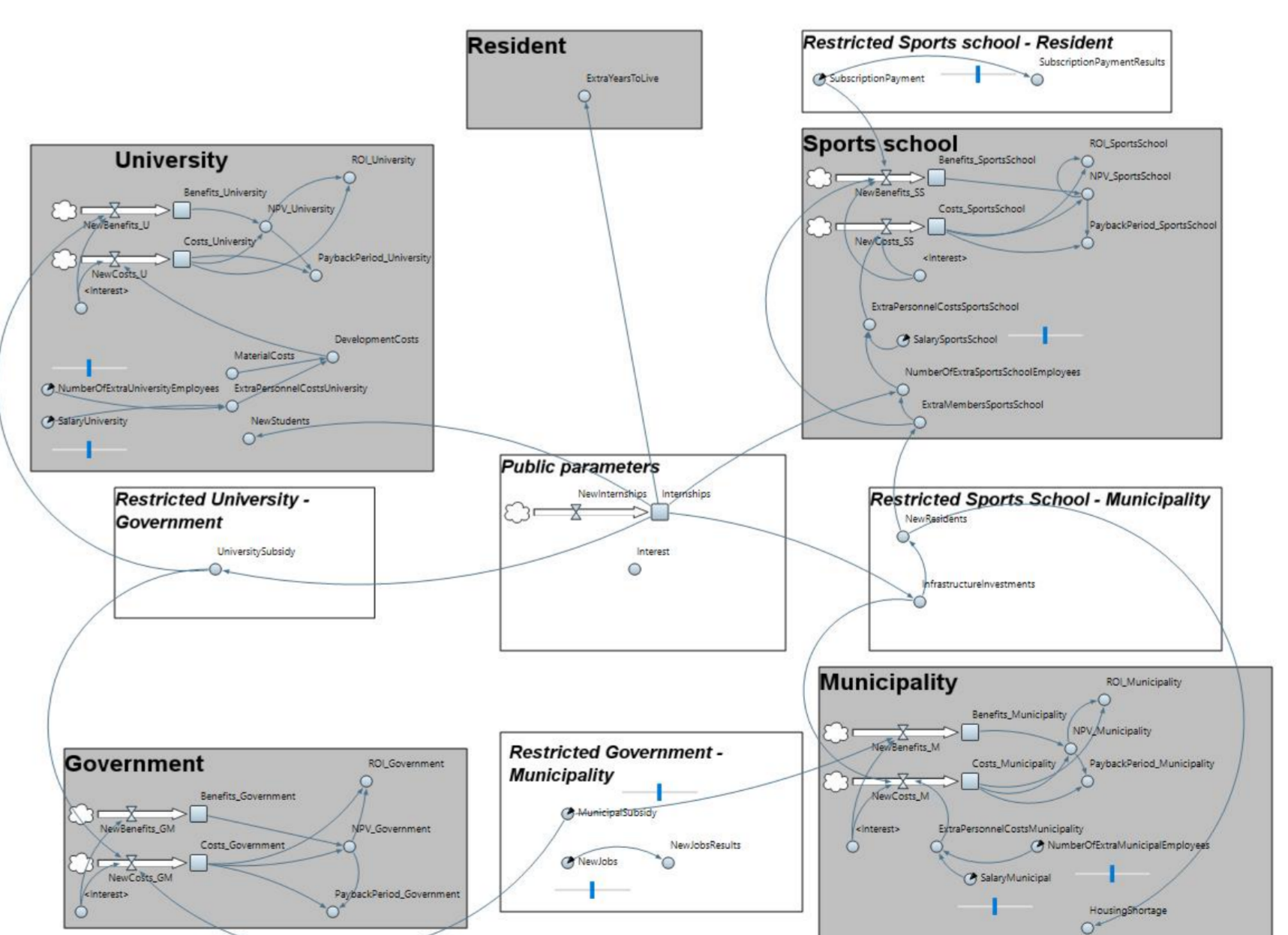

Results Municipality			
Financial	Social	Environmental	Other non-financial
<ul style="list-style-type: none"> <NewMunicipality> <RD_Municipality> <PaybackPeriod_Municipality> <InfrastructureInvestments> <ExtraPersonnelCostMunicipality> <MunicipalSubsidyDependentDiv> 	<ul style="list-style-type: none"> <NewResidents> <InflationChange> <NewJobResults> 		

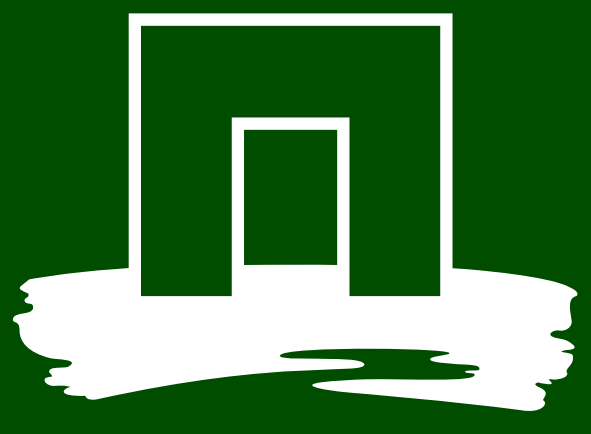

The governance and scalability of digital platforms in the agri-food industry

Daniela Robinson & Jos Bijman
Business Management & Organisation Group
Hollandseweg 1, Wageningen

Problem Statement

The agri-food sector is a major contributor to climate change; an estimated 30% of anthropogenic emissions originate from livestock and arable farming, fisheries, deforestation, land-use changes and food processing¹. Low-emission solutions depends on the effective resources use, data collection, and analysis of both farm and supply chain metrics about production and processes, facilitated through digital technologies. However, scaling digital technology usage among farmers and other agri-food stakeholders is not a trivial task.

Research Gap

Transparency of data usage, protection of privacy and constraining opportunistic behaviour by data platform owners, often controlled by multinational ICT providers, remain a concern for data providers (i.e. farmers) in using and sharing data through digital platforms²³⁴. While technical studies proliferate, the governance of these platforms, and how this affects the scaling and usage of digital platforms among various stakeholders, are scarcely considered.

Research question

How can governance encourage the scalability of digital platforms in the agrifood domain?

Digital Platform Governance in Agri-food

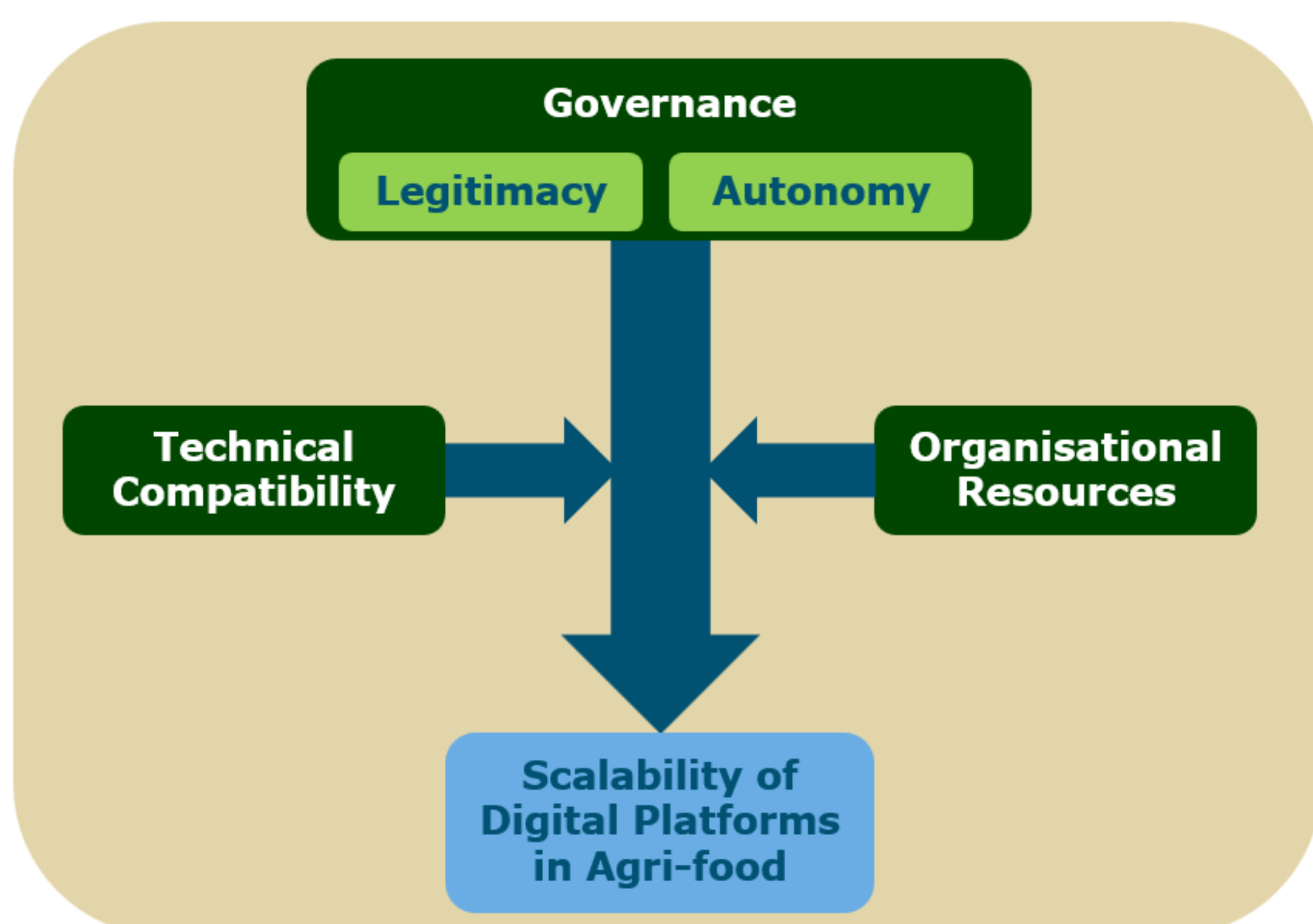

Figure 1. A simplified framework showing how effective governance, when combined with organisational resources and technical compatibility, can enable digital platforms in agri-food to scale (Source: authors' elaboration)



Figure 2. An example of members of the Join Data platform. The members of the cooperative help (or hinder) organisational legitimacy (Source: join-data.nl)

Methods

Research Case: Join Data

The agricultural sector is a cornerstone of the Dutch economy, generating €77 bn., contributing 7% of GDP. The sector is highly digitally coordinated, facilitated by the farmer-owned cooperative JoinData which arranges the exchange of digital information on yields, sustainability, fertility, animal health, nutrients, and laboratory reports between farmers and their business partners.

Empirical Approach

We adopt a single case study approach⁵. Semi-structured interviews will be conducted with key agri-food industry stakeholders. Using a thematic content analysis, the research focuses specifically on how the governance structure of Join Data influences its coordination tasks.

Conceptual Framework

We propose a farmer-owned cooperative governance model as a mechanism to establish effective platform governance, providing the basis for scaling digital platforms in agrifood.

- The governance model allows the organisation **legitimacy** to be a trusted mediator:
 - Credibility and social mandate as a cooperative itself
 - Draw on the credibility of the member cooperative and farmer associations
- Independence from the member organisations allows more **autonomous adaptations**:
 - Independent organisational structure allows more flexible decision making
 - Organisational resources and culture can be specialised towards digitalisation
- When **legitimate** and **autonomous** governance is combined with appropriate organisational resources and technical compatibility, this allows agri-food digital platforms to scale (expand the user base).

References

- ¹Nature (2023). Modern food emissions. *Nature Climate Change*, 13(3). <https://doi.org/10.1038/s41558-023-01643-2>
- ²Ciliberti, S., Frascarelli, A., Polenzani, B., Brunori, G., & Martino, G. (2024). Digitalisation strategies in the agri-food system: The case of PDO Parmigiano Reggiano. *Agricultural Systems*, 218, 103996. <https://doi.org/10.1016/j.agsy.2024.103996>
- ³Wolfert, S., Verdouw, C., Van Wassenae, L., Dolfsma, W., & Klerkx, L. (2023). Digital innovation ecosystems in agri-food: Design principles and organizational framework. *Agricultural Systems*, 204, 103558. <https://doi.org/10.1016/j.agsy.2022.103558>
- ⁴Zhang, A., Heath, R., McRobert, K., Llewellyn, R., Sanderson, J., Wiseman, L., & Rainbow, R. (2021). Who will benefit from big data? Farmers' perspective on willingness to share farm data. *Journal of Rural Studies*, 88, 346–353. <https://doi.org/10.1016/j.jrurstud.2021.08.006>
- ⁵Yin, R. K. (2014). *Case study research: Design and methods* (Fifth edition, [second printing]). Sage Publications.

Acknowledgements

This work was supported by Sector Plan Engineering II, funded by the Dutch ministry of Education, Culture, and Science (OCW).



EARLY STAGE SUSTAINABILITY ASSESSMENT OF BIOBASED AND CIRCULAR CHAINS

PI: Ellen Slegers

Team: Hanna Böpple, Oana Butuc, Furqan Hala, Dimas Nurseta, Ana Cavallo

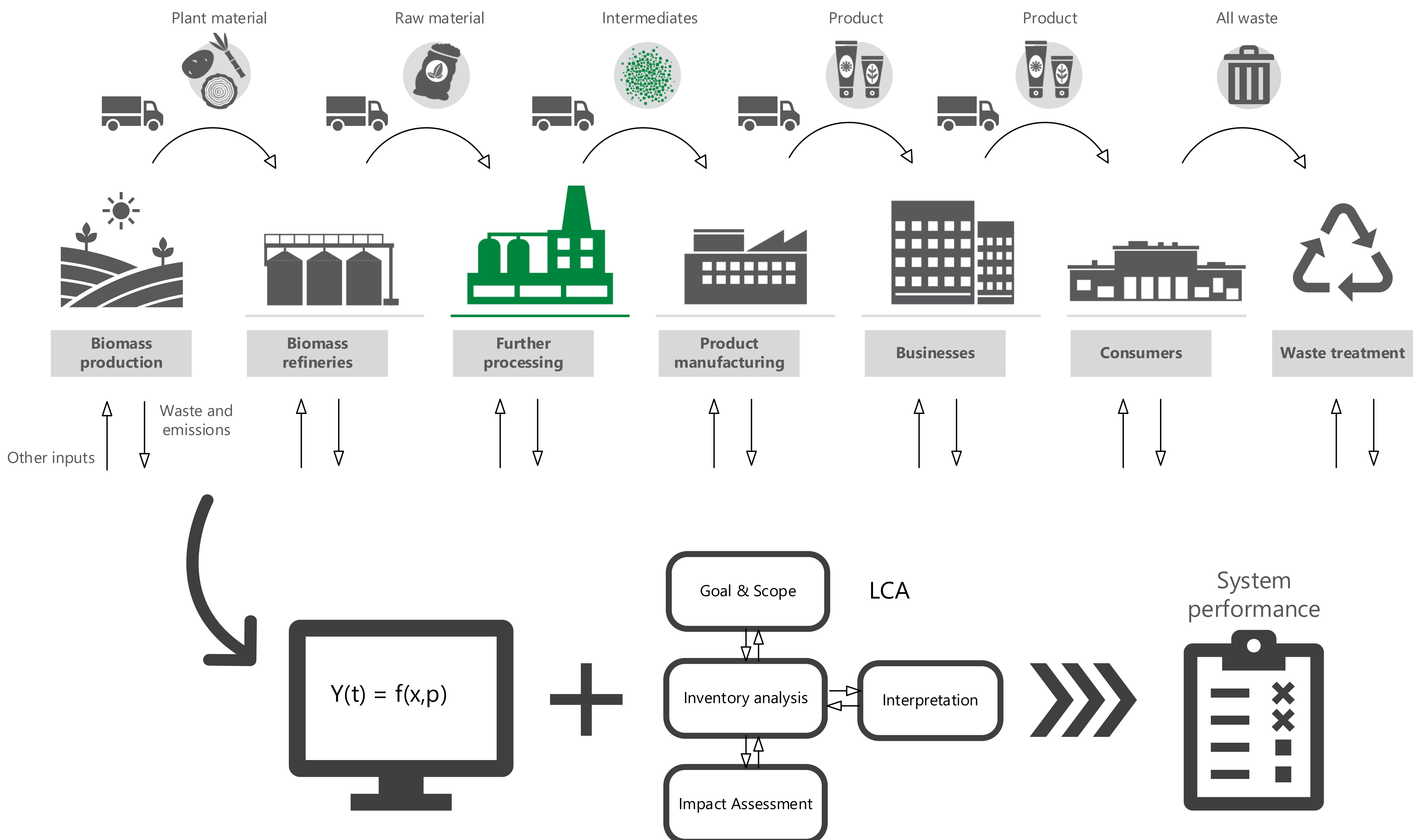

Research focus

- Quantitative sustainability evaluation of novel chains, TRL < 6
- Methods to evaluate new chain, dealing with many uncertainties
- Multi-method approach, integrating process systems engineering, life cycle methodologies (e.g. LCA), Operations Research
- Which strategic choices and operational variables contribute most to sustainability?
- Application areas: innovations in field of biobased and circular systems

Challenges

- Multiscale system-wide optimisation
- Limited insights in uncertainties of feedstock on logistics, connected processing and resulting sustainability
- Robust prospective assessment dealing with limited data
- Quantification of e.g. social aspects



The quay to circularity: A spatial-operational framework for ports in offshore wind decommissioning

Jade Vettters^{1*}, Onur Kilic², Jasper Veldman²

¹ Department of Engineering Management, Faculty of Business and Economics, University of Antwerp

² Department of Operations, Faculty of Economics and Business, University of Groningen

CONTEXT & FRAMEWORK

- Offshore wind farms are designed to last 20-25 years, so the first large wave is now approaching end-of-life.
- **Decommissioning** involves removing large components and routing them through ports into end-of-life waste treatment.
- **The port quay marks the handover point:** after unloading, the recycler assumes responsibility for handling, processing, and onward transport.
- For decommissioning activities, **port space** is both scarce and a dominant cost component for the recycler.
- Because port rental costs scale with occupied area and duration, **handling strategies** that increase spatial exposure can quickly become infeasible under limited port capacity.

The **objective** is therefore to assess which handling strategies remain feasible under constrained port space and realistic spatial, safety, and access constraints, using a **spatial-operational framework** that links port-side handling decisions to port feasibility.

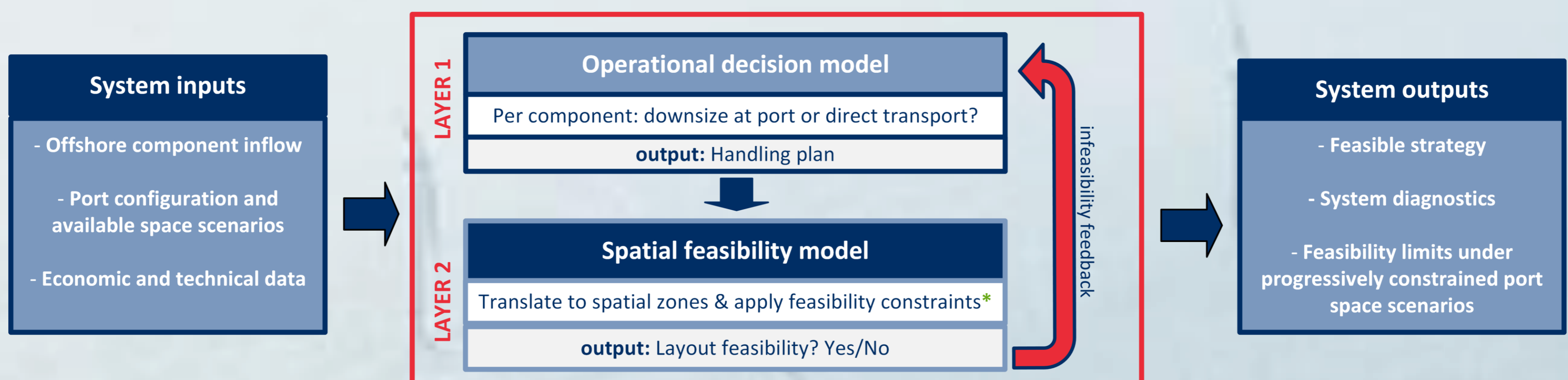

Feasibility constraints capture whether the spatial zones implied by a handling strategy can be accommodated within the available port area, subject to containment, non-overlap, safety and handling distances, and functional access and edge alignment.

ILLUSTRATIVE CASE STUDY

Case: Batch of seven 3 MW turbines for the port of Oostende (Belgium)

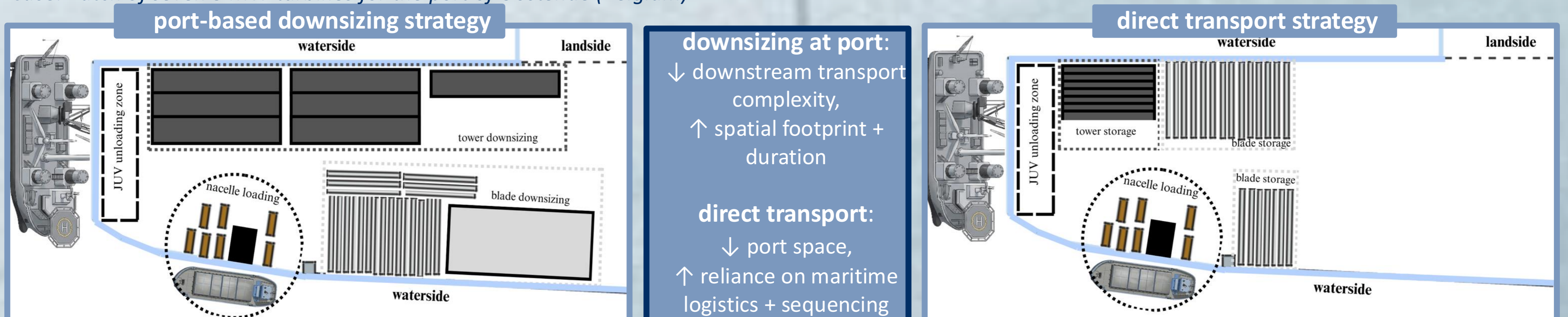

PRACTICAL TAKEAWAYS

- **Recycler:** handling strategies must be screened for spatial feasibility, as it may render economically attractive options infeasible.
- **Ports:** Readiness for decommissioning depends on the configuration and compatibility of functional activity zones and access conditions, not just total available area.
- **Policy:** Circularity requires port infrastructure that is spatially and operationally aligned with handling needs, as port-side bottlenecks can undermine feasibility and delay material recovery.

NEXT STEPS

1) operationalization framework

- **Quantifying spatial-operational relationships** by linking handling decisions to space and time requirements.
- **Identifying feasibility-driven tipping points** by determining when constrained layouts force shifts in handling strategies.
- **Assessing operational robustness** by evaluating how handling strategies perform under upstream uncertainty.

2) further research on offshore wind decommissioning

Coordination under fragmented waste treatment (RESLOEP): examine how coordination mechanisms across the end-of-life supply chain can prevent stranded components.



University of Antwerp
 ENVECON | Environmental Economics
 Research Group Engineering Management

✉ jade.vettters@uantwerpen.be

in /jvettters

FROM WASTE TO WATTS: ASSESSING THE USE OF SILICON KERF FOR BATTERY ANODE PRODUCTION

UNIVERSITY
OF TWENTE.

PhD. Candidates: Emanuel Zeferino; Hyunjong Lee and Ivan Trefilov

Chair of Manufacturing Systems, Faculty of Engineering Technology;

Mathematics of Multiscale Modeling and Simulation, Faculty EEMCS; Inorganic Material Science, MESA+ Institute for Nanotechnology, Faculty of Science and Technology, University of Twente, Drienerlolaan 5, Enschede 7522 NB, Netherlands ,
Email: e.f.s.zeferino@utwente.nl

INTRODUCTION & PROBLEM

- Silicon has become an important material for many industries, including semiconductor manufacturing [1].
- These industries produce pure silicon waste “kerf” that ranges between 45-55% [2].
- For sustainability reasons, scientists are exploring the use of these wastes to produce silicon anode used in battery systems [3,4].

OBJECTIVES

- **Assess the performance of pure Si-Kerf anodes in the battery systems.**
- Understanding recovered Si particle size variation vs anode performance.
- Understanding energy consumption during production of the Si anode, starting from the Si-Kerf recovering process.

METHODOLOGY

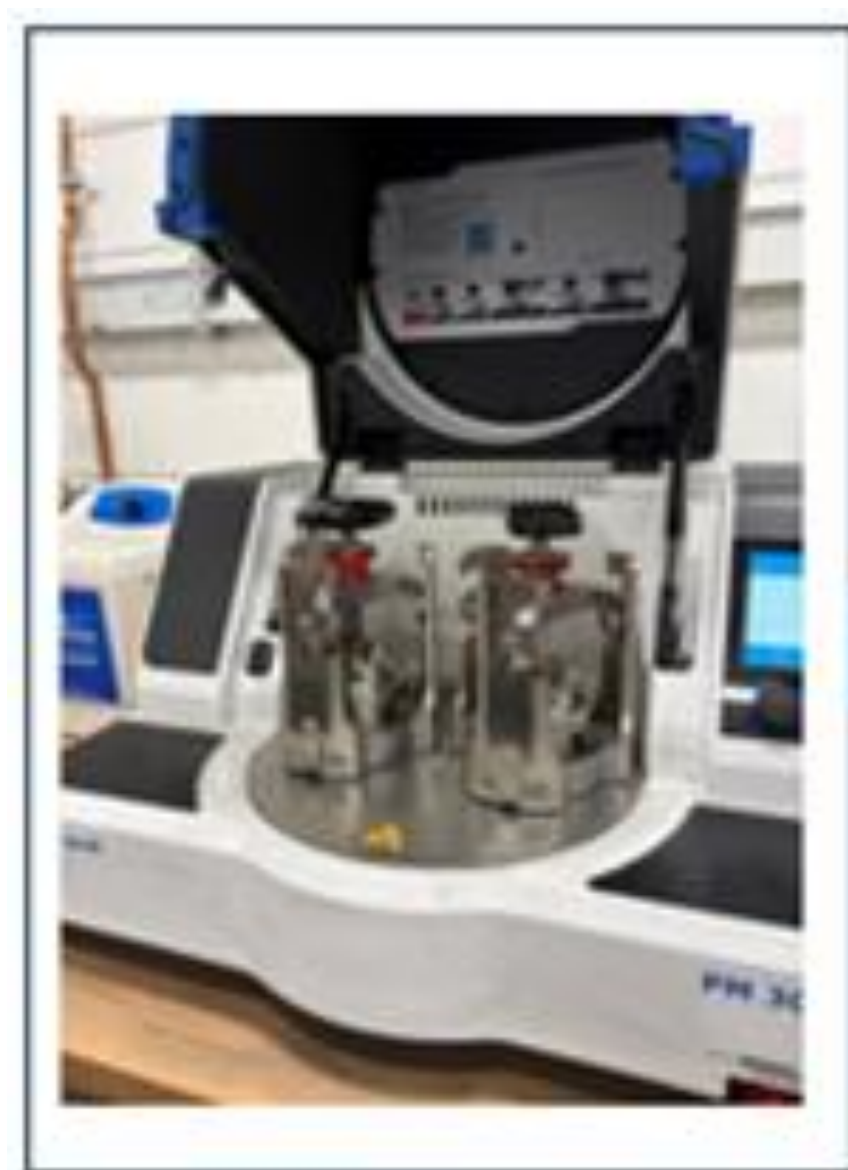

Ball Milling



Mixing



Coating & Drying

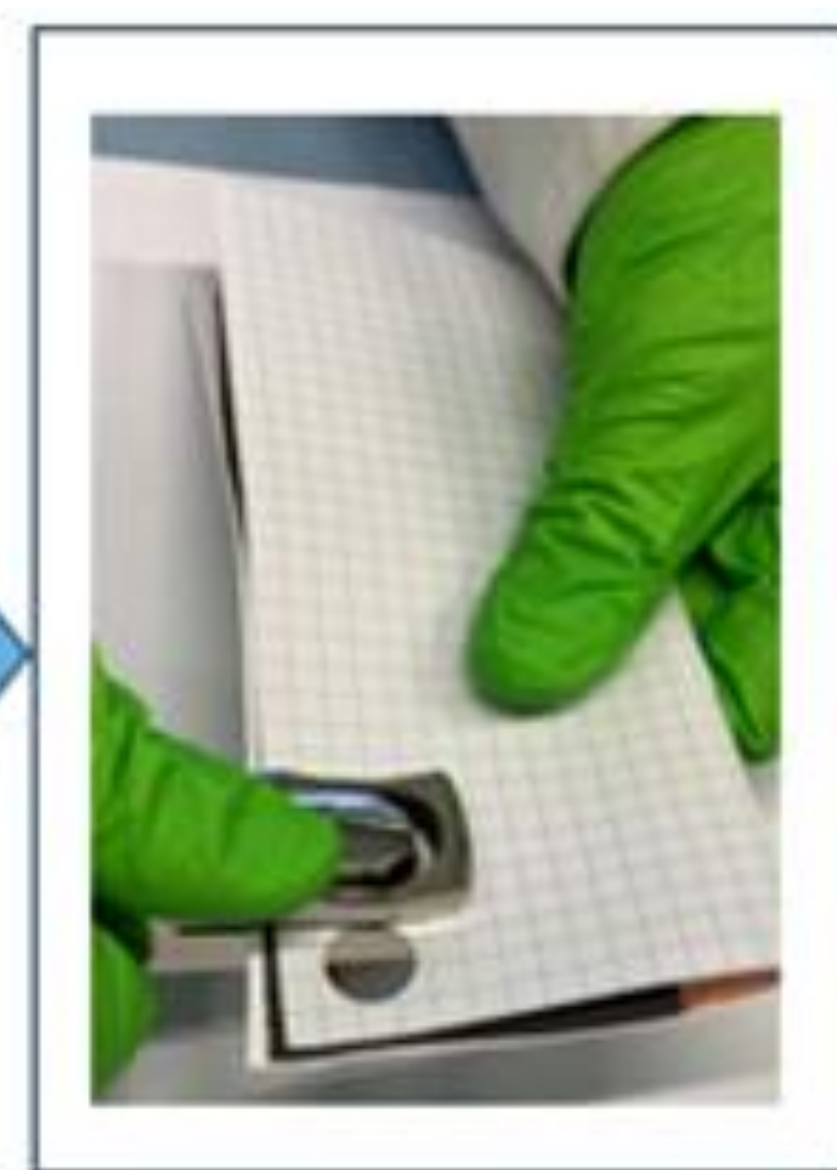

Cutting



Cell Assembly

RESULTS

PARTICLE SIZE DISTRIBUTION

- ~99,9% purity Si-kerf.
- Particle sizes were on average ~1 μ m .
- Some 15 μ m particles were present.

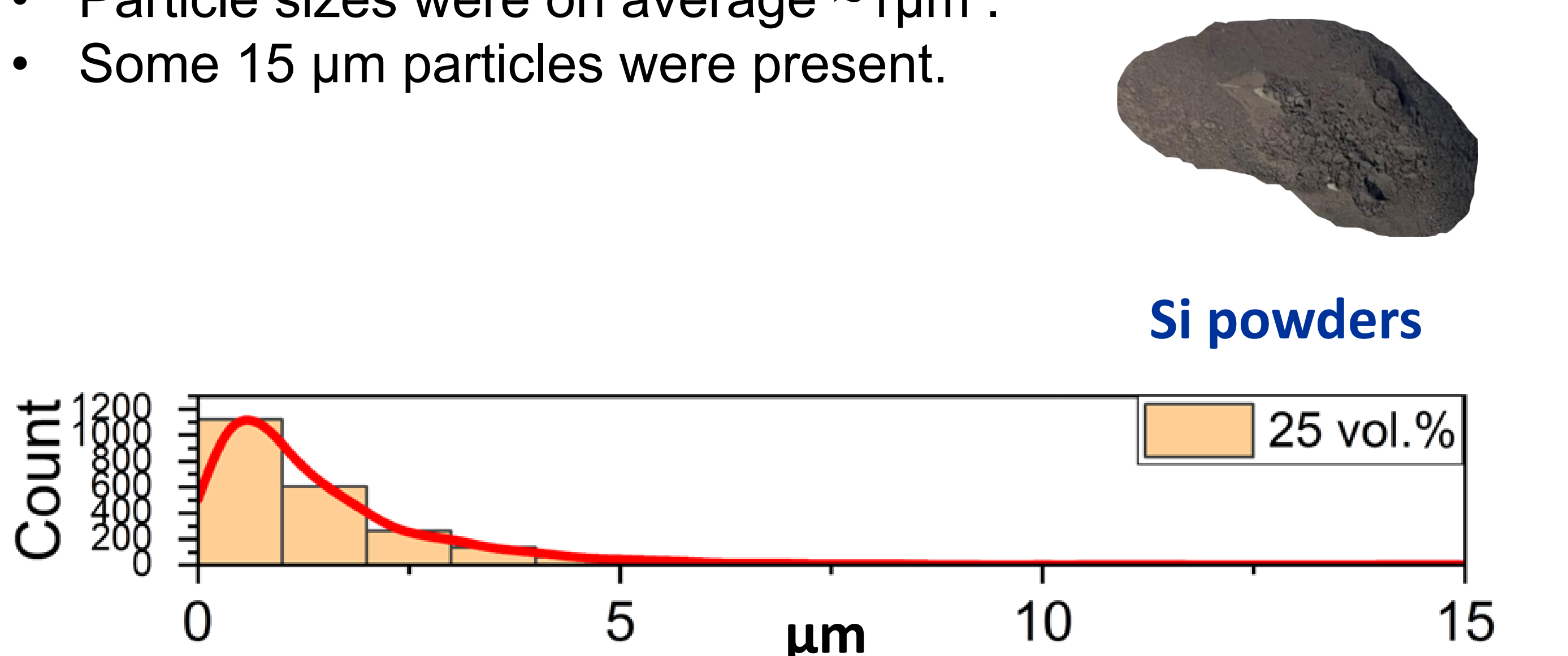

CELL PERFORMANCE

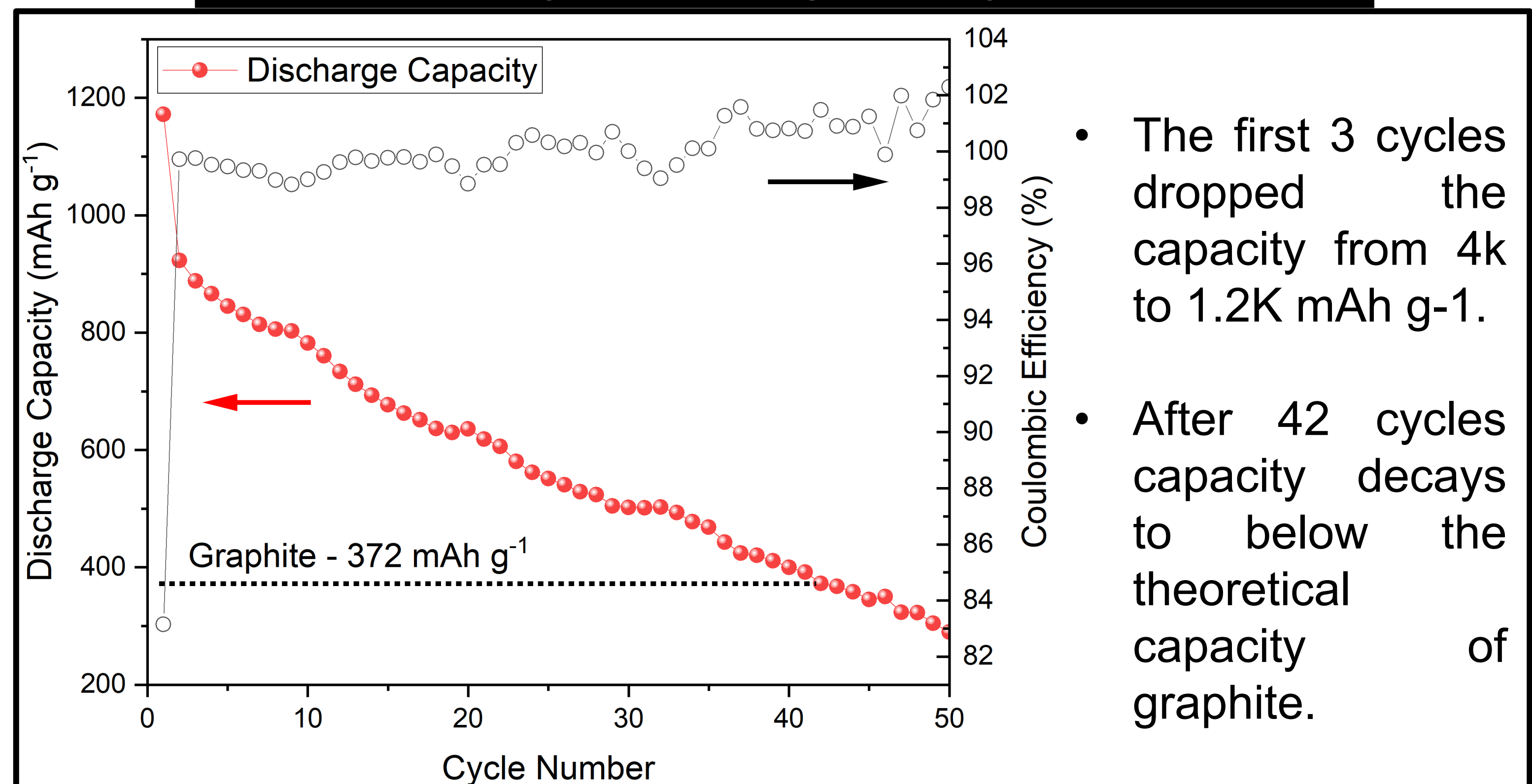

CONCLUSIONS & FUTURE WORK

- Si-kerf anode showed great performance for the thicker electrode, which shows its potential for next-Gen anode technology.
- The coulombic efficiency did not show an abnormal behavior and remained around 100%.
- Work with different set of parameters in the ball milling (e.g. rpm vs time) process to obtain the different particle sizes.
- Work with nano particles and compare performance of anodes of different particle sizes.

REFERENCES

Cui Y. 2021; Wagner et al., 2019; Sathiyamoorthy et al., 2025a; Sathiyamoorthy et al., 2025a.